



# FENIX RACING MISTRAL

DRIVER: GIORGIO FAVARETTO

DATE: 13 -15 APRIL

EVENT: ETS#3

TRACK: MADRID - GETAFE

### TRACK CONDITION:

COMPOSITION: ASPHALT / CARPET

TRACTION: LOW / MEDIUM / HIGH

LAYOUT: OPEN / MIXED / TECHNICAL

COMMENTS: COLD AND MOIST IN THE MORNING - JUST WARM IN AFTERNOON - 1 RUN PERFECT ABOUT 5PM

ENVIRONMENT: INDOOR / OUTDOOR

SURFACE: SMOOTH / BUMPY

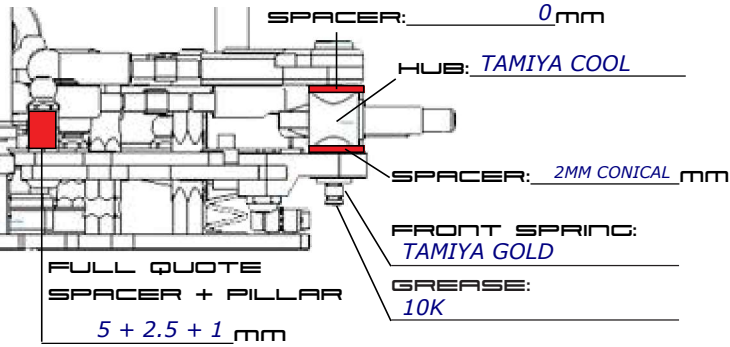

SHOCK ABSORBER: FENIX

PISTON: 4 HOLE

OIL: 500

SPRING: SILVER FENIX

LENGHT: LONG

ROLL DAMPER: DUAL

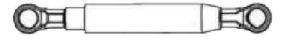

OIL / GREASE: 30 k

SIDE SPRING: GREEN RIDE

DIFF: GEAR

N BALL: \_\_\_\_\_

GREASE: FREE

SETTING: \_\_\_\_\_



REAR RIDE HEIGHT \_\_\_\_\_ mm  
 MIDDLE RIDE HEIGHT \_\_\_\_\_ mm

NOTE to self: DROOP HEIGHT \_\_\_\_\_ mm  
 Need to experiment harder side springs and harder damper (100K)

Marco chassis works great for open tracks

VOLANTE special front end must be used

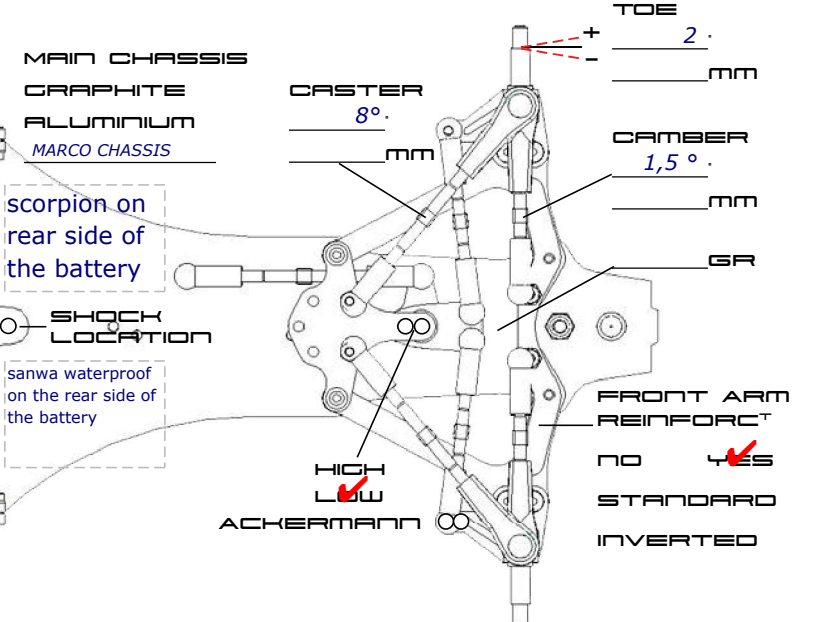
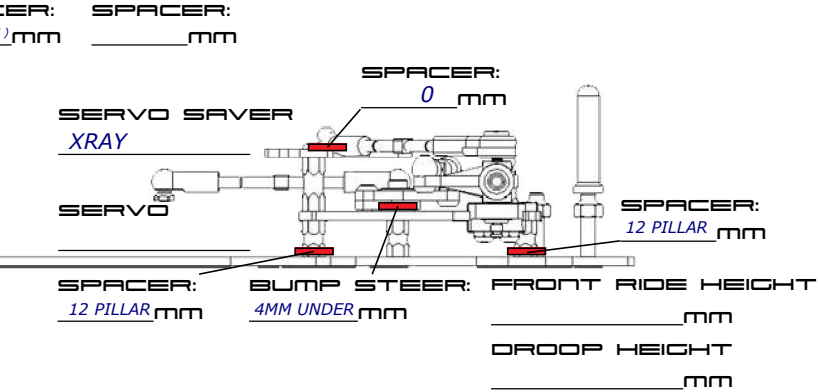
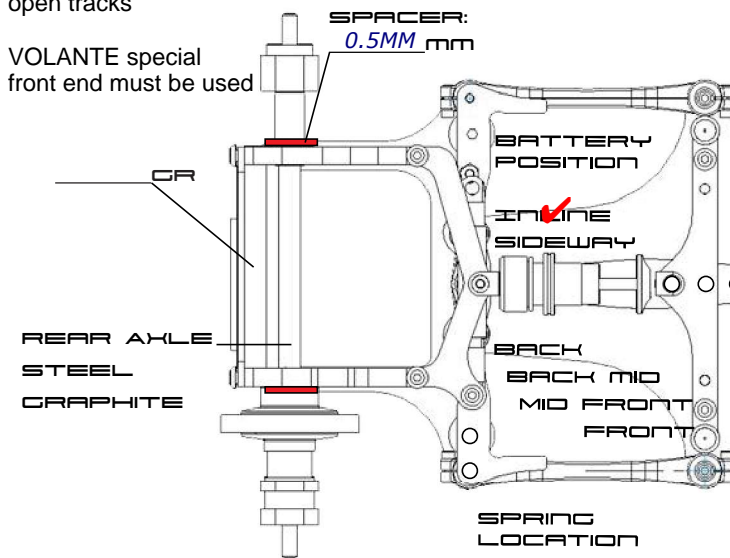

Giorgio Favaretto / Arn0 - PetitRC.com

### TIRES

TIRE: VOLANTE ETS

INSERT: \_\_\_\_\_

ADDITIVE: ETS #3

ADDIT. TIME: last 15 minutes at 100°

FRONT: 1H - 60° REAR: 1H - 100°



### ELECTRONICS

MOTOR: SCORPION ETS

ESC SETTING: \_\_\_\_\_

BATTERY: GENS HV 5K

RADIO: SANWA

TH EPA: \_\_\_\_\_

BRAKE EPA: 64

STEERING EPA: 74 EXP -30%

GEARING: 49 / 84 64 DP

### AERODYNAMICS

BODY: PHIGAMMA 2

FRONT WING: FENIX ETS LEGAL

REAR WING: SERPENT 1 ETS LEGAL

WEIGHT: 1080 GR

Qualify 12laps in 5.27.241

C Final - 3rd best run 11 - 5.02.893 best lap in 25.886  
I could have made way better. in the best final I made a bad move and have to climb from last to 3rd...