



FENIX RACING MISTRAL

DRIVER: Giorgio Favaretto

DATE: 28-29 April 2018

EVENT: Swiss Nat Rd 1

TRACK: CHIASSO

TRACK CONDITION:

COMPOSITION: ASPHALT / CARPET

TRACTION: LOW / MEDIUM / HIGH

LAYOUT: OPEN / MIXED / TECHNICAL

COMMENTS: A little shower in Sunday morning - Track was clean and in good condition.

ENVIRONMENT: INDOOR / OUTDOOR

SURFACE: SMOOTH / BUMPY

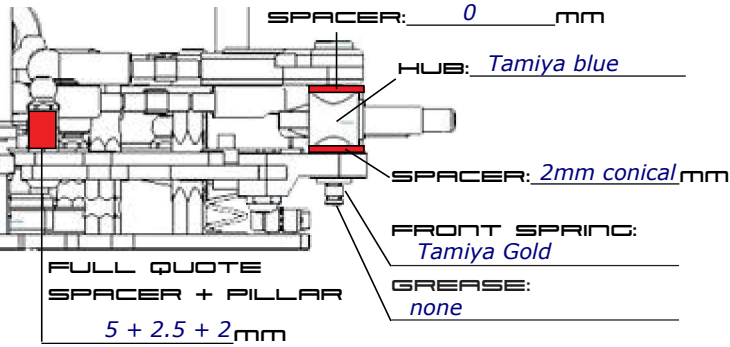

SHOCK ABSORBER: Fenix

PISTON: 4

OIL: 650

SPRING: Fenix Silver

LENGTH: long vers

ROLL DAMPER: Fenix 2

OIL / GREASE: 30 K

SIDE SPRING: Tamiya silver

DIFF: Sphere

N BALL: 16

GREASE: Virgin

SETTING: med-tigh



REAR RIDE HEIGHT _____ mm

MIDDLE RIDE HEIGHT _____ mm

DROOP HEIGHT _____ mm

SPACER: 6 mm

SPACER: 27mm mm

SERVO SAVER: Xray

SPACER: 12 pillar mm

SPACER: 0 mm

BUMP STEER: _____ mm

FRONT RIDE HEIGHT _____ mm

DROOP HEIGHT _____ mm

Car was perfect, but I did not drive in Chiasso since long time. Track is F..king technical and missing the proper line kill your lap time. 15.948 was my best, 19 in 5.16.564 in quali.

Lovely race - lovely car

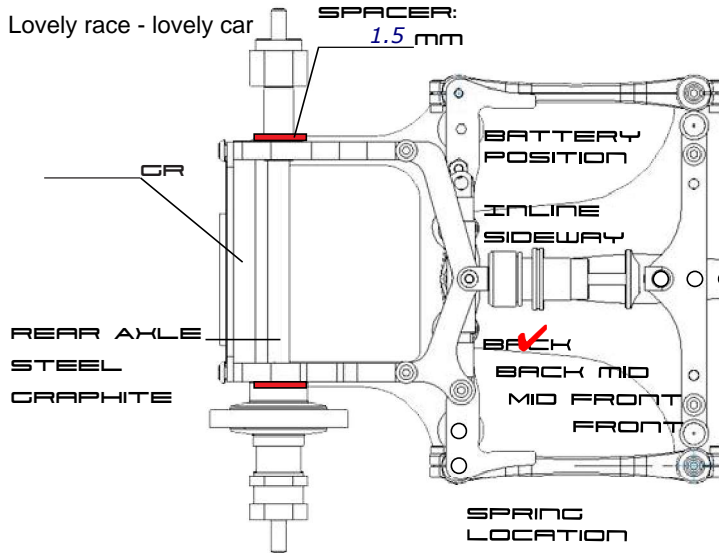

MAIN CHASSIS
GRAPHITE
ALUMINIUM
Graphite Slim

CASTER: 6°

HIGH
LOW
ACKERMANN

TOE
+ 2
_____ mm

CAMBER
1
_____ mm

0 GR

FRONT ARM REINFORC'T
NO YES
STANDARD INVERTED

TIRES

TIRE: Mandatory Ride GR

INSERT: _____
ADDITIVE: None

ADDIT. TIME: _____
FRONT: 55° - 30min REAR: 80° - 30

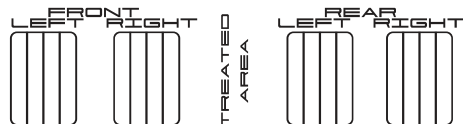

ELECTRONICS

MOTOR: SRCCA HW

ESC SETTING: _____

BATTERY: GensAce 5K - 7.4

RADIO: Sanwa ZZ

TH EPA: 100%

BRAKE EPA: 80%

STEERING EPA: 80%

GEARING: 84 / 28 _____ 64 DP

AERODYNAMICS

BODY: Fenix Phigamma 2

FRONT WING: Fenix ETS

REAR WING: Fenix ETS

WEIGHT: 1065

Perfect car, almost good but slow driver. 8th in the A-main. Probably the best Mistral ever driven in Chiasso. Lovely