



Name _____

Date _____

Event _____

Composition Asphalt Indoor Surface Smooth Medium Bumpy Layout Tight Mixed Open Humidity _____
 Carpet Outdoor Traction Low Medium High Track temp. _____ Air temp. _____

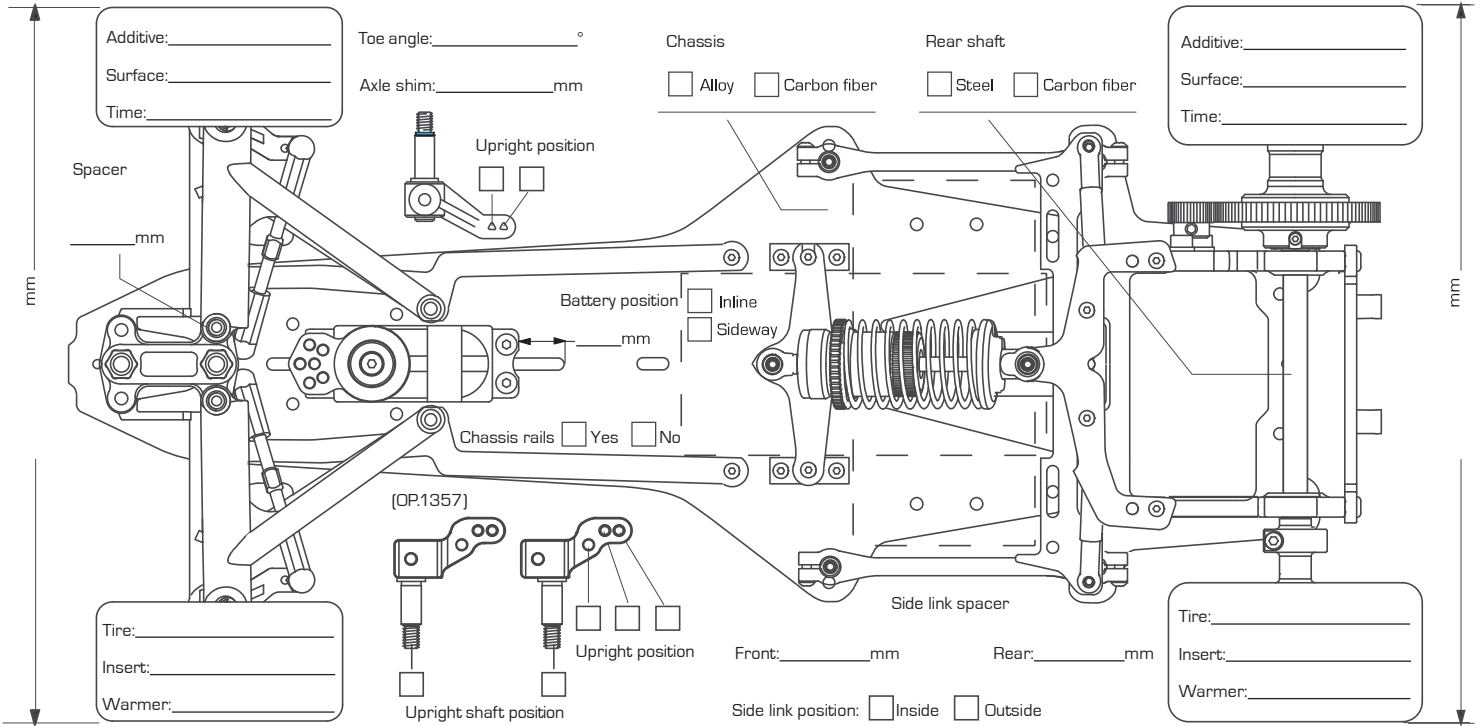

Belt: Yes No

Castor: _____ °

Spacer: _____ mm

Spacer: _____ mm

Wheelbase: Short Long

Camber: _____ °

Camberlink: Short Long

Camberlink shims: _____ mm

Spring: _____

Ackermann: _____

Front



Ground clearance: _____ mm

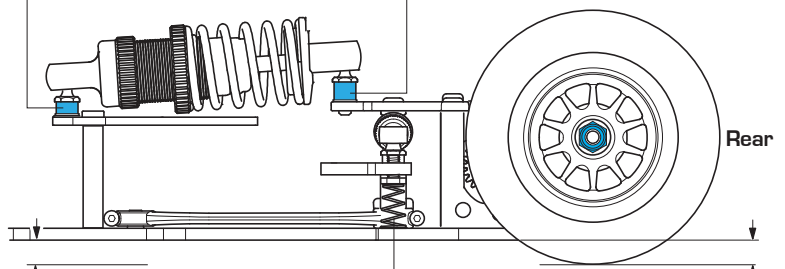

Rear

Ground clearance: _____ mm

Roll spring: _____

Preload - L: _____ - R: _____

Ground clearance: _____ mm

Droop: _____ mm

Diff grease: _____

Bearing: Standard Thrust

IFS Front

Droop: _____ mm

Damper oil: _____ cst

Spring: Silver (Hard)
 Dark Grey (Medium)
 Blue (Soft)
 Yellow (Extra Soft)

Shock tower hole:

Bottom Middle Top

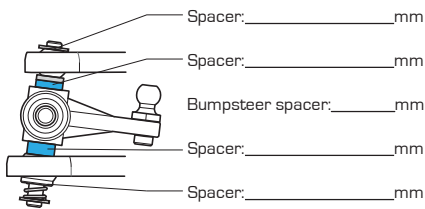

Rear Ground Clearance

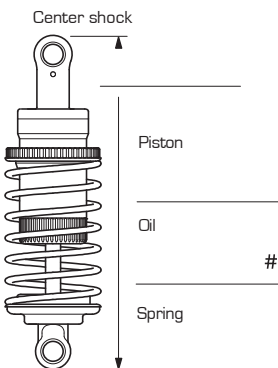
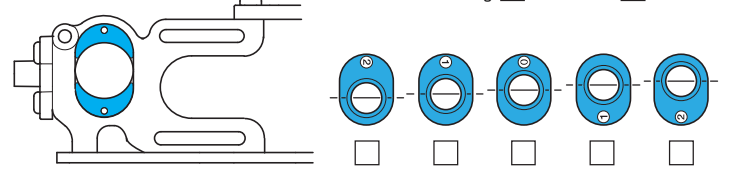

Notes

Motor: _____

Timing: _____

Spur/Pinion: _____

ESC: _____

ESC Setting: _____

Battery: _____

Body: _____

Front wing: _____

Front wing setting: _____

Rear wing: _____

Rear wing height: _____

Rear wing setting: _____

Notes