

# CARPET KNIFE Generation X Setup Sheet

Modified A-Main

Driver : Jilles Groskamp  
 Race : Las Vegas iic 2008  
 Date : Aug 2008  
 Track Type : Fast wide  
high bite

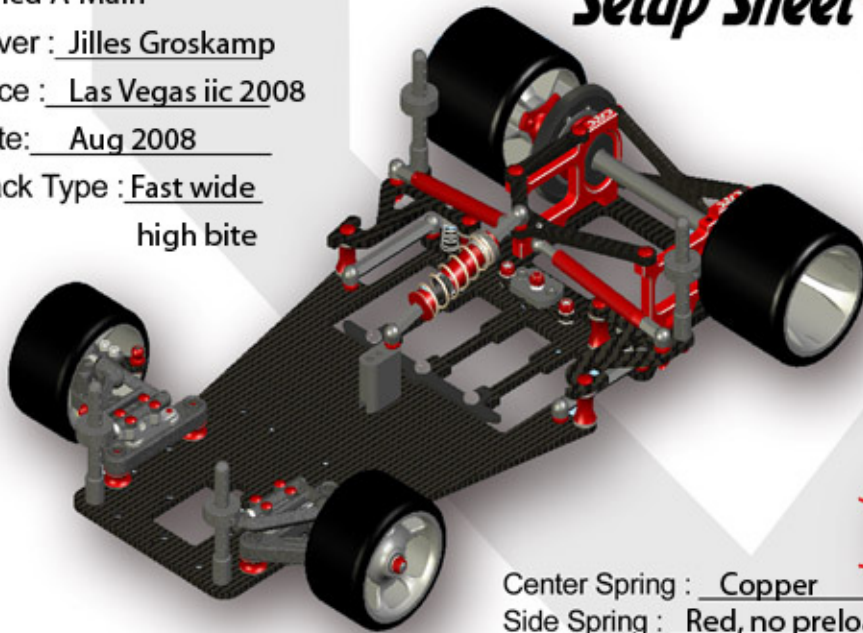

## Rear End



Battery Position: Forward

Center Spring : Copper  
 Side Spring : Red, no preload  
 Damper Tube : 20000  
 Shock Oil : \_\_\_\_\_ wt

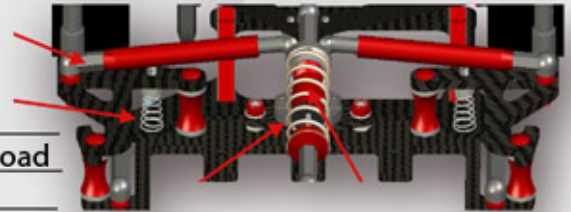

Gilles used the new Encore shock coming soon from CRC

## Front End

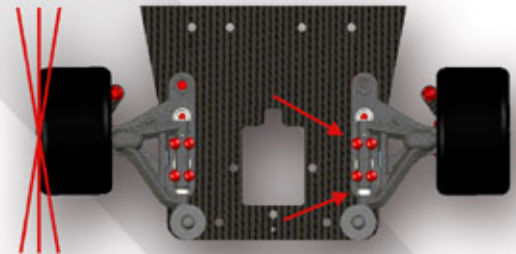
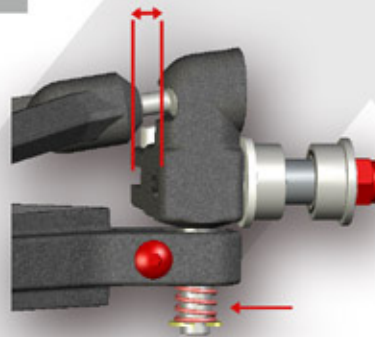
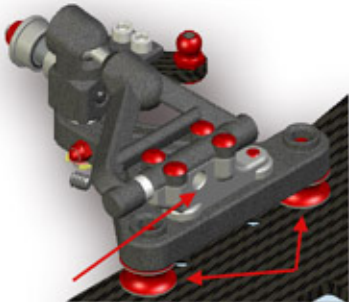

Ride Height Adjuster : long ball upper arm  
 Caster Block : 5 - dynamic 0  
 Front Spring : .45mm, little load  
 Camber : 0.5 mm 0  
 2 shims each front axle

Caster Shims : full caster  
 Toe Angle : 0 0

## Tires - Ride Height - Droop

Front Tire Cmpd : Magenta  
 Tire Size : 1.65  
 Treatment :: glued

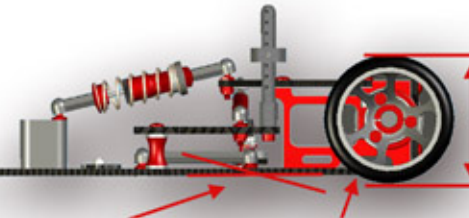
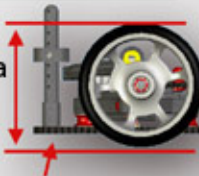

Rear Tire Cmpd : yellow  
 Tire Size : 1.70  
 Treatment :: full wash

Ride Height : Front 3.5 mm Center : 4 mm Rear : 4.25 mm  
 Rear Pod Droop : 0.5 (but flat at race weight)

Other Notes: New CRC exclusive short diff hub with the 3349 Brushless Pod conversion for perfect center motor placement.



CALANDRA RACING CONCEPTS  
 6785 MARTIN STREET ROME, NY 13440, USA  
 PHONE & FAX: (315) 338-0867

<http://www.teamcrc.com>  
[info@teamcrc.com](mailto:info@teamcrc.com)