

# CARPET KNIFE™ Generation-XL<sub>ipo</sub> SETUP SHEET

## Pro-Strut Front End Setting

### Camber + Front Spring

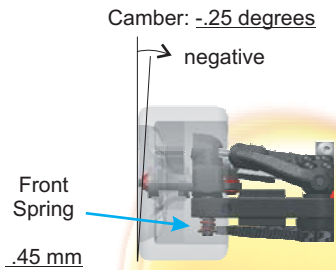

### King pin length

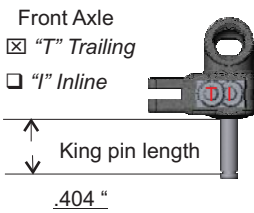

- Caster Shim Position:  
 0 Forward  
 1 Forward  
 2 Forward  
 3 Forward
- Dynamic Caster Block:  
 0 Degree  
 5 Degree  
 10 Degree

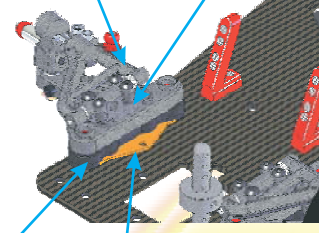

- Coarse ride height spacer:  
 3 mm  
 4 mm  
 5 mm
- Fine ride height spacer:  
 .25 mm white  
 .50 mm yellow  
 .75 mm orange
- Option Parts Used:  
 3277 Graphite brace  
 Dual Arm -  long  short  
 Pin Brace

### Rear Chassis Adjustments

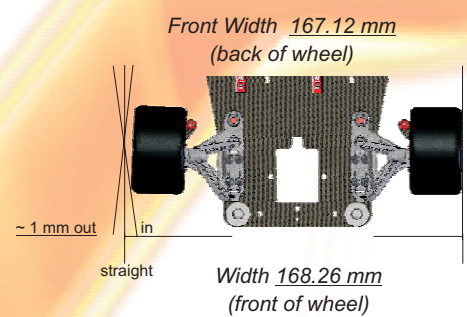
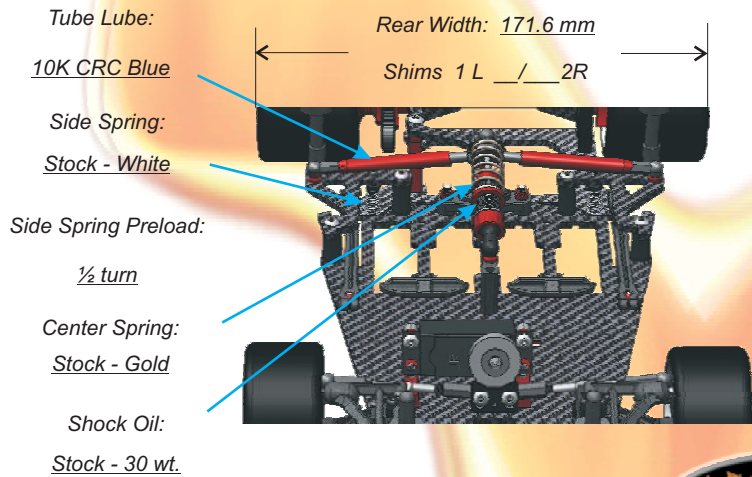

### Adjustable Battery Position

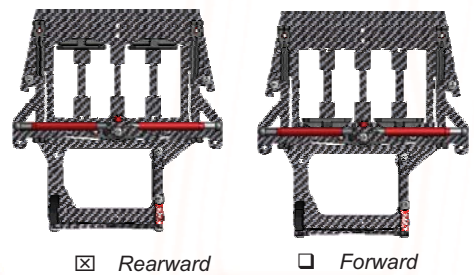

### Tires + Ride Height



- |                                                                                                                                                                                 |                                                                                                                                                                                     |
|---------------------------------------------------------------------------------------------------------------------------------------------------------------------------------|-------------------------------------------------------------------------------------------------------------------------------------------------------------------------------------|
| <p>Front Tires<br/> <b>Size:</b> 1.595" (40.5 mm)<br/> <b>Compound:</b> CRC Black<br/> <b>Shore:</b> 40 shore<br/> <b>Additive:</b> Jack-O-Latern<br/> <b>CA Glue:</b> None</p> | <p>Rear Tires<br/> <b>Size:</b> 1.64" (41.6 mm)<br/> <b>Compound:</b> CRC Yellow<br/> <b>Shore:</b> 32 shore<br/> <b>Additive:</b> Jack-the-snipper<br/> <b>CA Glue:</b> safety</p> |
|---------------------------------------------------------------------------------------------------------------------------------------------------------------------------------|-------------------------------------------------------------------------------------------------------------------------------------------------------------------------------------|

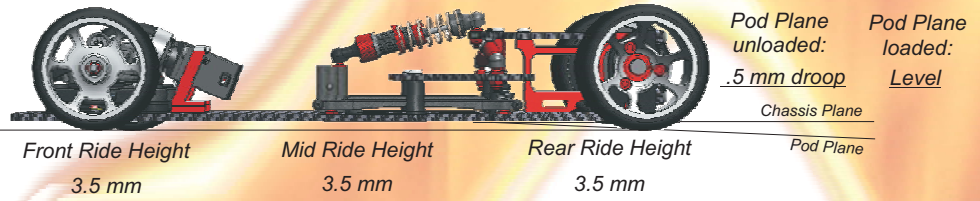

### Power + Electronics

Motor Putnam Propulsion 17.5 Gearing 49 / 76 Temp 145 degrees  
 Speed Control: Advanced Black Diamond Profile #4-Whoop Ass Battery: Power Push

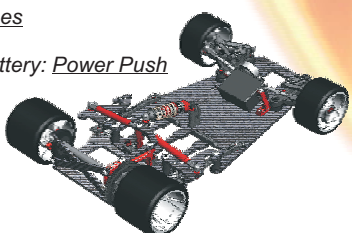

Driver: Brian "Dumper" Wynn  
 Race: 2009 IIC - Las Vegas  
 Date: September 12  
 Result: T.Q. + 1st  
 Track Type: High grip CRC Fastrak-smooth  
 Grip Level: Low - Med - High - Insane  
 Body: Black Art R8C  
 Notes: New CRC Gen-XL was dialed the minute I unloaded off the truck (airplane).  
Car was stable but a lot of steering. New  
Encore shock was maintenance free.

**Calandra Racing Concepts, Inc.**  
 6785 Martin Street ~ Rome, NY 13440  
 Tel + Fax ~ 315-338-0867  
 info@teamcrc.com ~ www.teamcrc.com