



Part# 74905 SP12M Tubedamper Kit

Team Corally's tubedampers will give an upgrade to your SP12M or SP12G3. In combination with #74900 VCS Micro Shock Kit it will give you a superb driving to let the competition behind you. A complete set is also available:
#00055 Tubedamper Conversion Kit containing:
#74900 SP12M VCS Micro Shock
#74905 SP12M Tubedamper Kit
#75154 SP12M Motorpod
#74865 SP12M Damperplate
#74873 SP12M Radioplate

Tubedamper Parts

- 1x tube
- 1x tube connector
- 2x ballcup
- 2x balljoint
- 2x M3 nut

Step 1

Mount the balljoints.
It's necessary to use the optional parts:

- #75154 SP12M Motorpod** (not especially necessary)
- #74865 SP12M Damperplate**
- #74873 SP12M Radioplate**

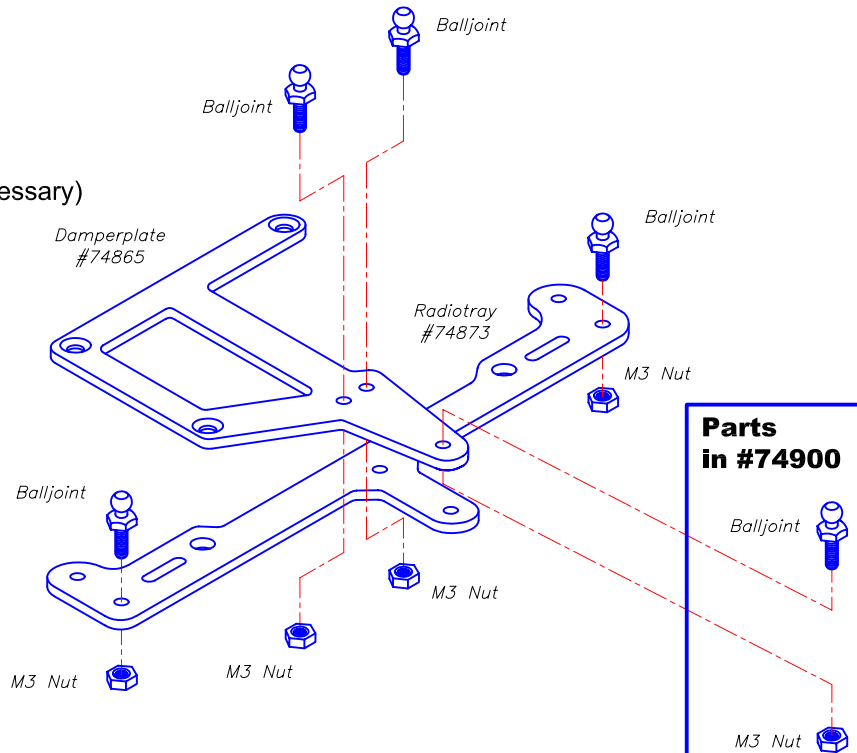

Step 2

Built 2 identical Tubedampers

Part 1:
- Screw a **ballcup**, the **tubeconnector** and the **tube** together.

Part 2:
- Screw a **ballcup** and **dampershaft** together.

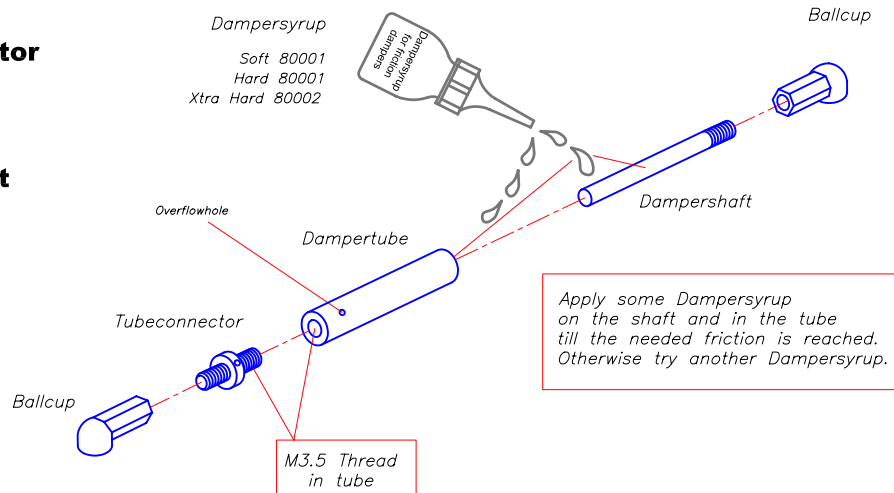

Step 3

Snap the **ballcups** of the **dampers** on the **balljoints**.

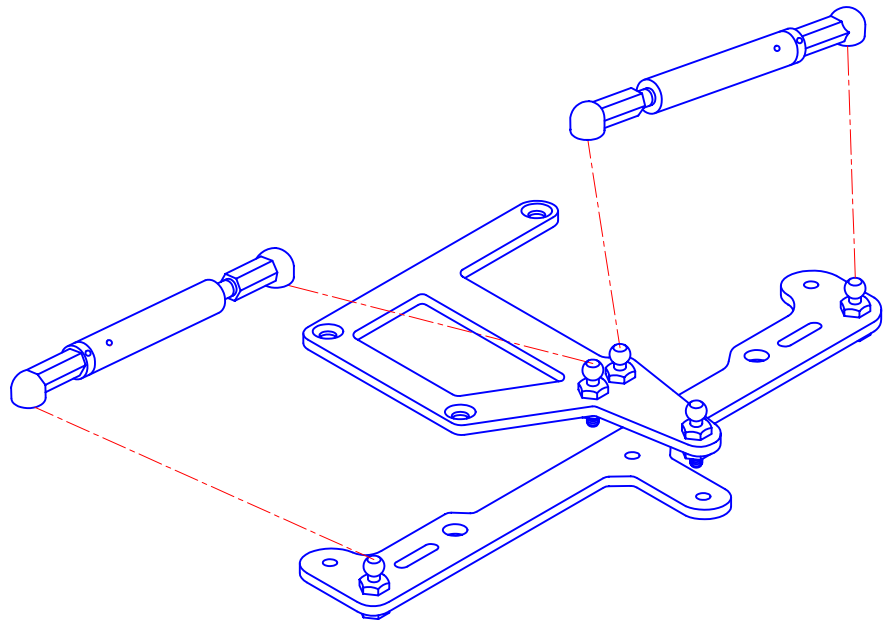

Step 4 (with #74900)

Assembled with
kit #74900

And snap also the **VCS Micro Shock**
to the **ball ends**.

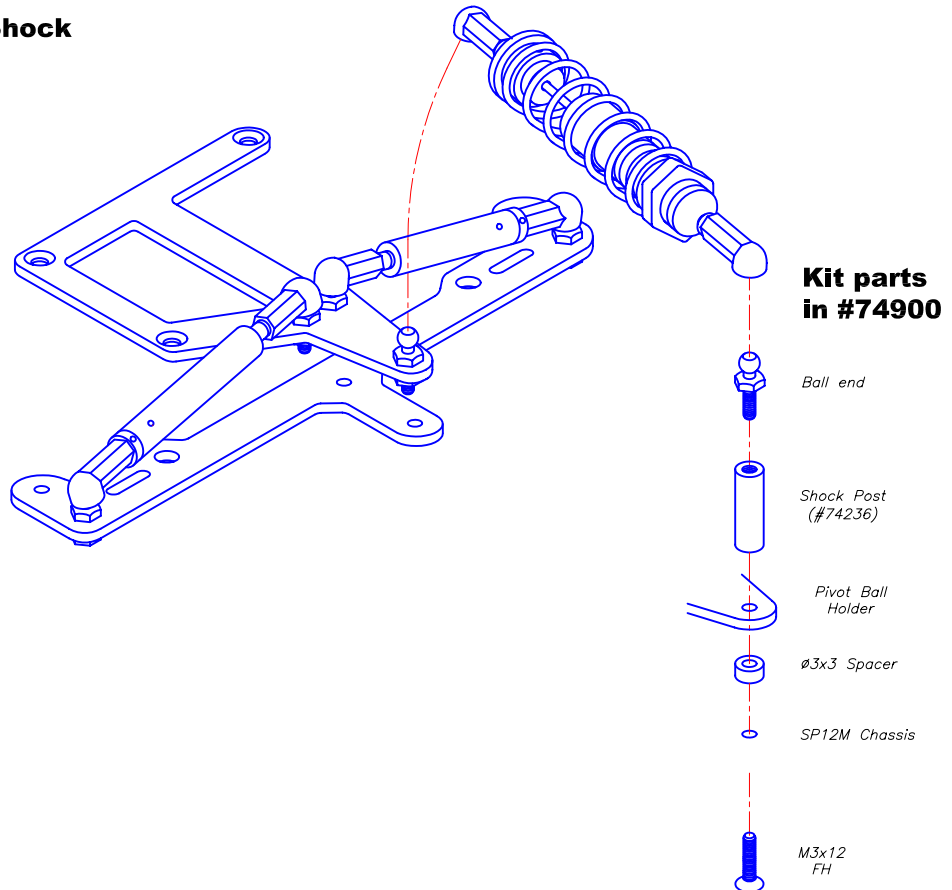

Contact



Corally R/C BV
Ploegstraat 49
3319 LG Dordrecht
Holland

<http://www.corally.com>
e-mail: team@corally.com
Fax: (+31) 78 621 26 89