



Driver: GERRIT VAN SWIJGENHOVEN

Track / City: BRUSSELS

HIGH PERFORMANCE 1:10 ELECTRIC TOURING CAR

SETUP SHEET

Event: ICM - RACES Date: 15-11-09

Front

Caster 3° Downstops 7 mm Oil 45 WT
 Toe-out 0° Anti-roll bar / Piston 3 HOLE (TAM)
 Camber -2.0° Front width STOCK mm Rebound 100%
 Ride Height 5 Front drive SPOOL Spring 17.0 lbs
 Wishbone 35 Front pulley 36 Shock tower STOCK
 Wheelbase MID Steering ALU Steering block STOCK
 F Mount 1.5 F Height shims 0 mm F WB shims 1.4 mm
 R Mount 1.0 R Height shims 0 mm R WB shims 1.4 mm

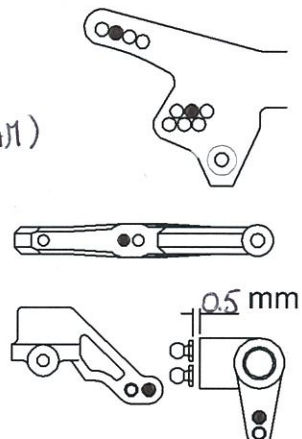

Rear

Anti-squat / Downstops 6 mm Oil 30 WT
 Toe-in 2.5° Anti-roll bar / Piston 3 HOLE (TAM)
 Camber -2.0° Rear width STOCK mm Rebound 100%
 Ride Height 5 Center pulley 21 T Spring 16.9 lbs
 Wishbone 35 Rear pulley 36 T Shock tower STOCK
 Wheelbase MID Upright 0° toe-in
 F Mount 0.5 F Height shims 0 mm F WB shims 1.4 mm
 R Mount 2.0 R Height shims 0 mm R WB shims 1.4 mm

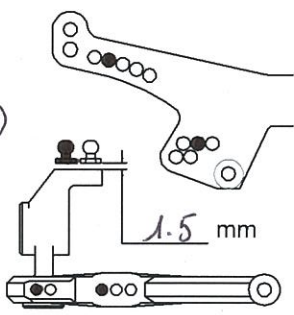

Others

Tires YTEC CPX PRE-GLUED Tire additive CS
 Motor NOSRAM 10.5 Motor setup 12.5 ROTOR Spur / Pinion 102 T / 30 T
 Radio FUTABA 4PK Servo S9551 ESC NOSRAM SPEC RACING
 Body MAZDA SPEED Wing STOCK
 Lead Weights 135 g

Weight balance

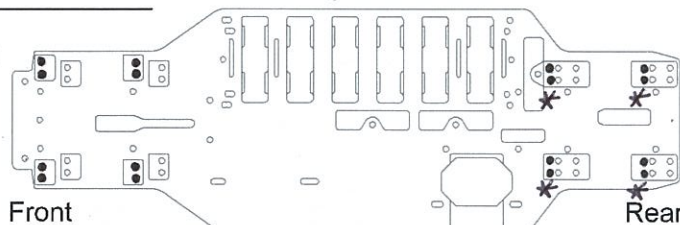

Track Conditions

Surface CARPET
 Traction MEDIUM
 Temp. /

Notes * SHORT WHEELB.
 Main A Finish 2 Qual. Pos. 3 Time _____ Laps _____
507 FRONT BELT - 177 REAR BELT (TAM 415)

Race Comments