



Driver: Mark Strasnick

Track / City: R/C Excitement

HIGH PERFORMANCE 1:10 ELECTRIC TOURING CAR

SETUP SHEET

Event: _____ Date: _____

Front

Caster 6 degrees Downstops _____ mm Oil 60 WT

Toe-out _____ Anti-roll bar _____ Piston 1.1

Camber 2 degrees Front width _____ mm Rebound _____

Ride Height 4.5 mm Front drive _____ Spring 33 lbs

Wishbone _____ Front pulley _____ Shock tower _____

Wheelbase _____ Steering _____ Steering block _____

F Coupler _____ F coupler shims _____ Coupler clamp _____

R Coupler _____ R coupler shims _____ Clamp shims _____

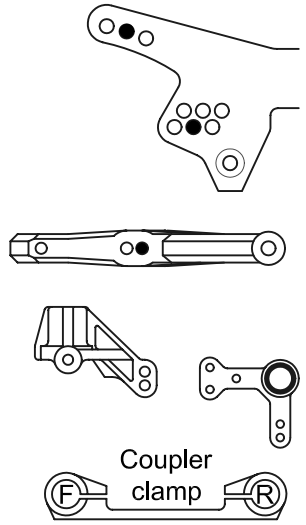

Rear

Anti-squat _____ Downstops _____ mm Oil 40 WT

Toe-in _____ Anti-roll bar _____ Piston 1.1

Camber _____ Rear width _____ mm Rebound _____

Ride Height 4.5 mm Center pulley _____ T Spring 26 lbs

Wishbone _____ Rear pulley _____ T Shock tower _____

Wheelbase _____ Upright _____ toe-in

F Coupler _____ F coupler shims _____ Coupler clamp _____

R Coupler _____ R coupler shims _____ Clamp shims _____

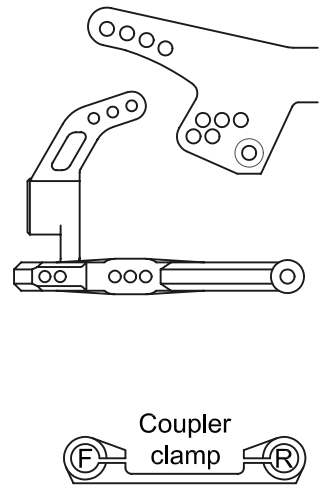

Others

Tires Jaco 26mm Wrap. Front: Double Pink/Orange Rear: Double Pink Tire additive _____

Motor _____ Motor setup _____ Spur / Pinion _____ T / _____ T

Radio _____ Servo _____ ESC _____

Body Parma Mohawk .020 Wing _____

Lead Weights _____ g

Weight balance

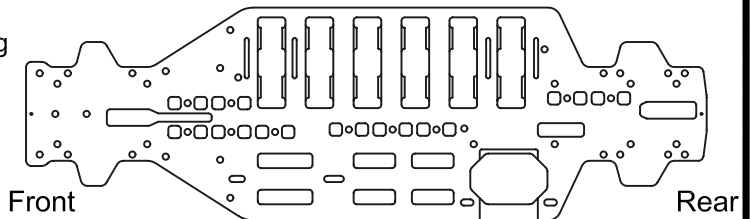

Track Conditions

Surface _____

Traction _____

Temp. _____

Notes _____

Race Comments

Main _____ Finish _____ Qual. Pos. _____ Time _____ Laps _____