

**TC 01625**



HIGH PERFORMANCE 1:10 ELECTRIC TOURING CAR

**SETUP SHEET**

**Driver:** Tim Streefkerk

**Track / City:** AMCA Apeldoorn

**Event:** ETS Round 5 2012

**Date:** 1-6-2012/ 2-6-2012

**Front**

Caster 3° (alu) Downstops 5 mm Oil 35 WT  
 Toe-out 0 Anti-roll bar Silver mm Piston std  
 Camber 1,5° Front width std mm Rebound 10%  
 Ride Height 5,5 mm Front drive Spool Spring 14,9 lbs  
 Wishbone standard Front pulley 36T Shock tower std  
 Wheelbase Middle Steering - Steering block std  
 F Mount std F Height shims 0 mm F WB shims \_\_\_\_\_ mm  
 R Mount std R Height shims 0 mm R WB shims \_\_\_\_\_ mm

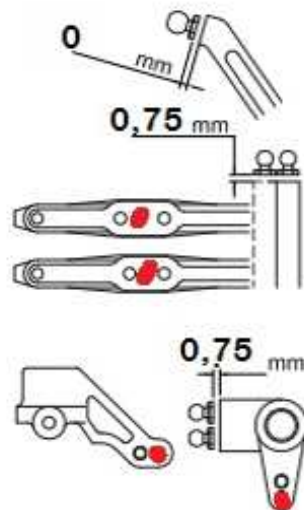

**Rear**

Anti-squat no Downstops 5 mm Oil 35 WT  
 Toe-in 2,5° Anti-roll bar Brass mm Piston std  
 Camber 2° Rear width 190 mm Rebound 10%  
 Ride Height 5,5 mm Center pulley 21 T Spring 11,8 lbs  
 Wishbone std Rear pulley 36 T Shock tower std  
 Wheelbase Middle Upright std toe-In \_\_\_\_\_

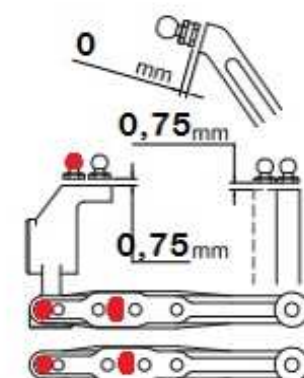

**Others**

Tires Ride Re 32 Tire additive Corally Tc5  
 Motor SP13,5 Motor setup \_\_\_\_\_ Spur / Pinion 75 T / 32 T  
 Radio Sanwa MT-4 Servo Fitec ESC SP cirtix stock  
 Body LTC-R Wing normal Weight balance \_\_\_\_\_  
 Lead Weights \_\_\_\_\_ g

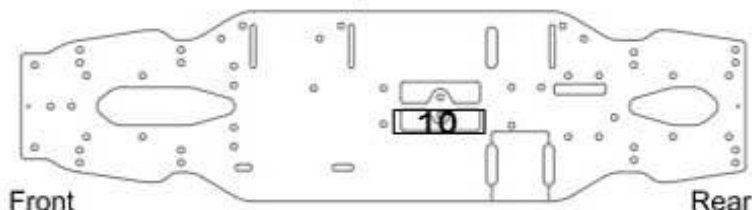

**Track Conditions**

Surface Asphalt  
 Traction High  
 Temp. 15  
 Notes \_\_\_\_\_  
 \_\_\_\_\_

**Race Comments**

Main \_\_\_\_\_ Finish \_\_\_\_\_ Qual. Pos. \_\_\_\_\_ Time \_\_\_\_\_ Laps \_\_\_\_\_