

LAB TE04 Setup Sheet

Race	
Track	
Name	
City	
Date	

TRACK CONDITIONS

Air Temp.	Track Temp.			
Qualifying	Best Lap	Final Position	Race Length	
		sec	min	
TRACK CONDITION	<input type="checkbox"/> Carpet	<input type="checkbox"/> Asphalt	<input type="checkbox"/> Indoor	<input type="checkbox"/> Outdoor
	<input type="checkbox"/> Bumpy	<input type="checkbox"/> Smooth		
	<input type="checkbox"/> Technical	<input type="checkbox"/> Mixed	<input type="checkbox"/> Fast	
TRACTION	<input type="checkbox"/> Low	<input type="checkbox"/> Medium	<input type="checkbox"/> High	

FRONT REAR

GEAR DIFF.	GEAR DIFF.
<input type="checkbox"/>	<input type="checkbox"/>
CST	CST

SPOOL	
NUMBER OF GEAR	
<input type="checkbox"/> 2	<input type="checkbox"/> 4
<input type="checkbox"/> 2	<input type="checkbox"/> 4

PINION	SPUR
T	T
INT. RATIO	RATIO
2.0	

OIL	OIL
PISTON	PISTON
SPRING	SPRING
REBOUND	REBOUND

TIRES	
WHEEL	
ADDITIVE	
SURFACE	

CHASSIS TYPE	ATS
<input type="checkbox"/> Carbon	<input type="checkbox"/> Aluminium
ATS SHIM	mm

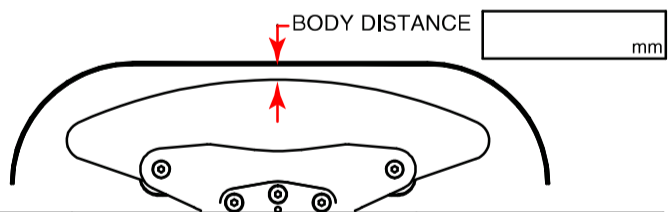

BODY		
WING		
UPPER DESK	<input type="checkbox"/> STD	<input type="checkbox"/> BRIDGE
BRIDGE LINK	<input type="checkbox"/> FRONT	<input type="checkbox"/> REAR

Flex Control Plate	A	B	C
<input type="checkbox"/>	<input type="checkbox"/>	<input type="checkbox"/>	<input type="checkbox"/>

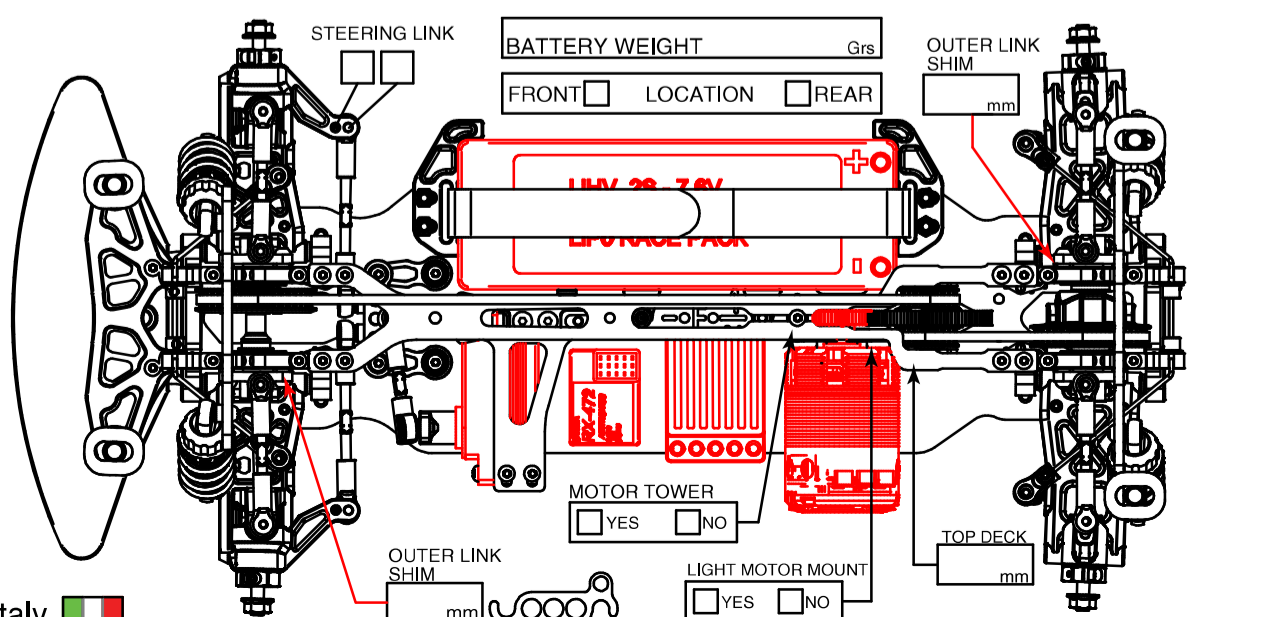
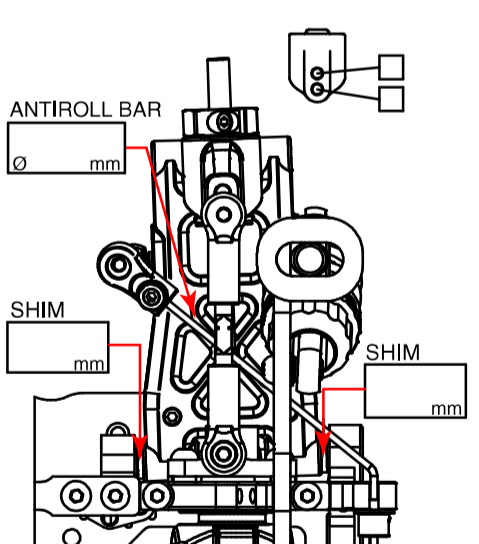
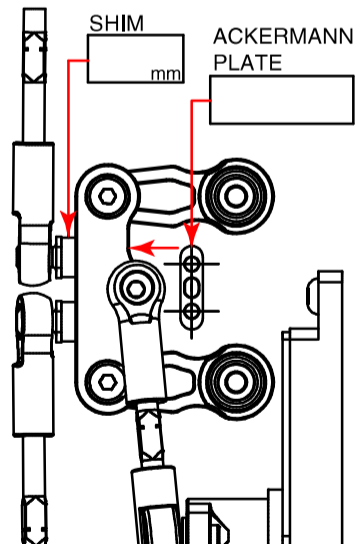
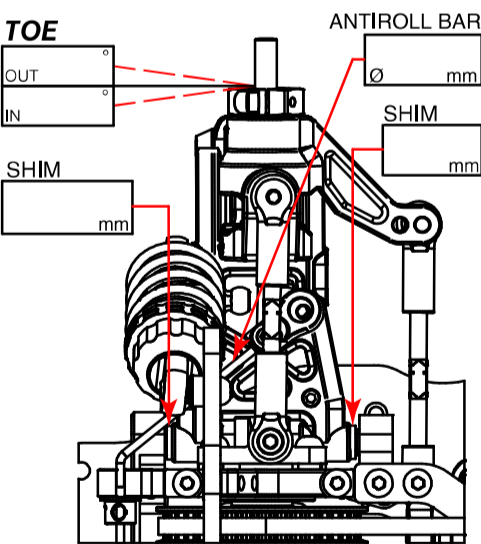
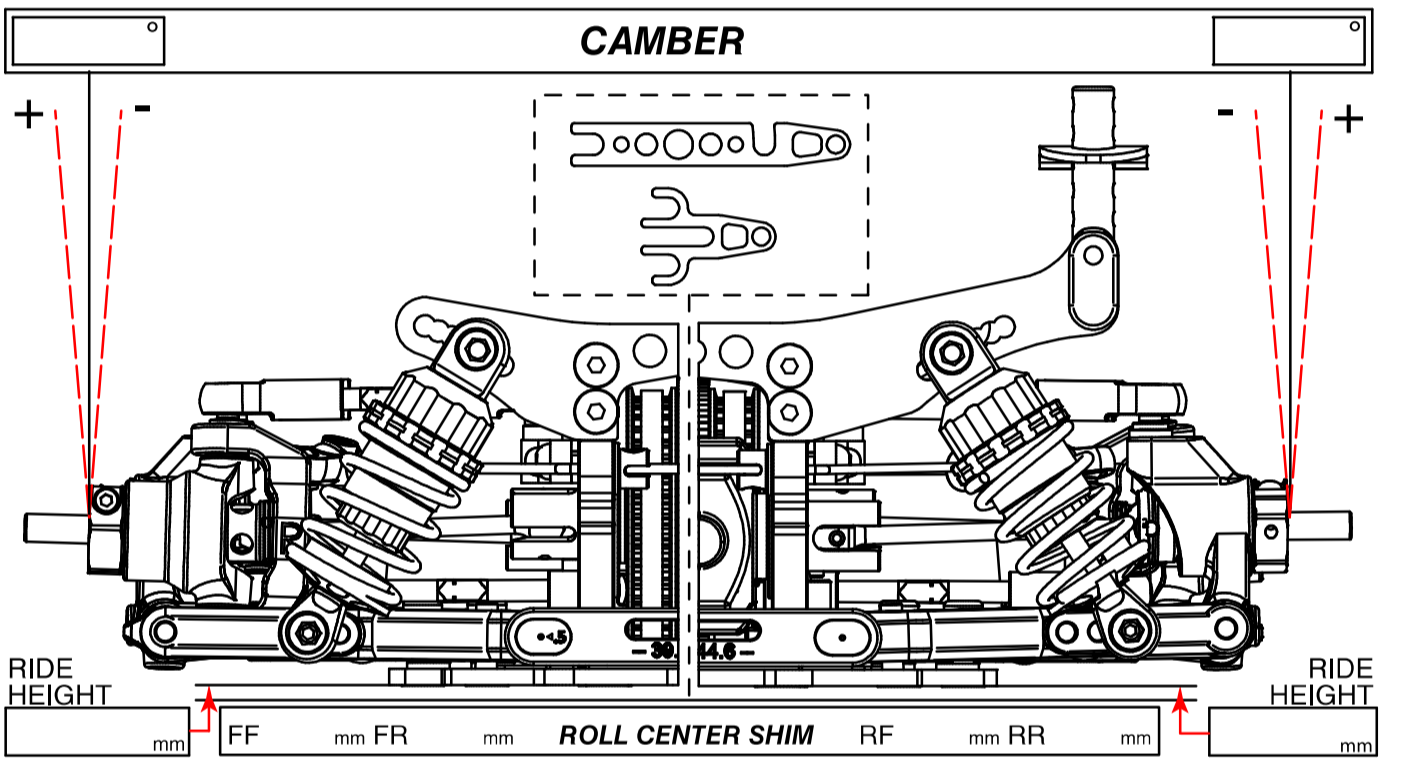
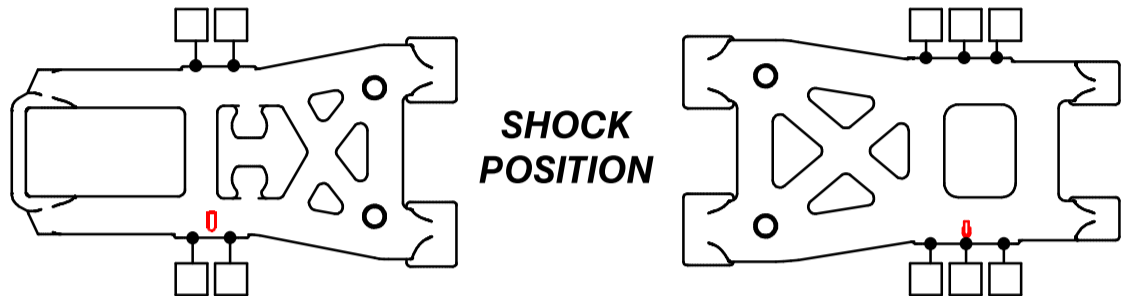
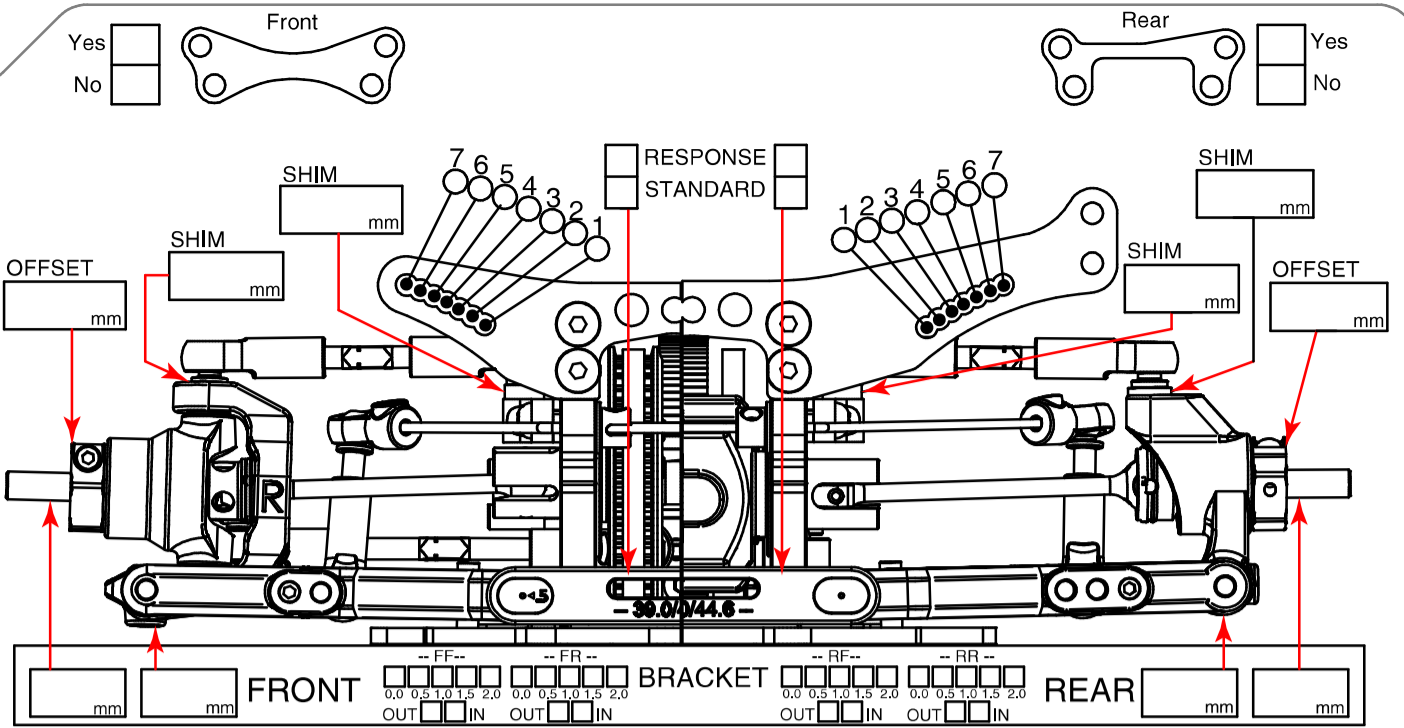

NOTES

Made in Italy