

NAME \_\_\_\_\_  
 COUNTRY \_\_\_\_\_  
 RACE \_\_\_\_\_  
 TRACK \_\_\_\_\_

DATE \_\_\_\_\_ TEMP.°C AIR / TRACK \_\_\_\_\_ /  
 TRACK CONDITION TECHNICAL  MIXED  FAST   
 TRACTION LOW  MEDIUM  HIGH

### FRONT

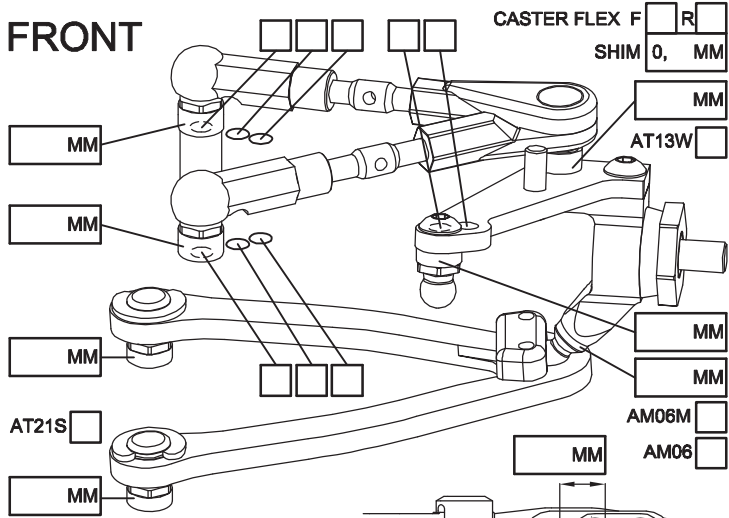

CAMBER ANGLE / ° \_\_\_\_\_  
 CASTER ANGLE / ° \_\_\_\_\_  
 TOE ANGLE / ° \_\_\_\_\_  
 RIDE HEIGHT / MM \_\_\_\_\_  
 DOWNSTOP / MM \_\_\_\_\_  
 UPSTOP / MM \_\_\_\_\_  
 STABILIZER Ø / MM \_\_\_\_\_  
 LOW ARM C04M    
 STEERING ARM STD    
 WHEEL SPACER / MM \_\_\_\_\_  
 FRONT DRIVE BALL DIFF  GD3  SPOOL  GD2   
 DIFF OIL \_\_\_\_\_ DIFF WASHERS \_\_\_\_\_  
 DOGBONE DRIVE ST17-1  ST11  ST12  BB  ST02

**SHOCKS SET**

ROTOR STD    
 SPRING STD  S   
 DAMPER D2.1    
 ACTION SYM.  ASYM.   
 SRS/RHS ARR. I  II

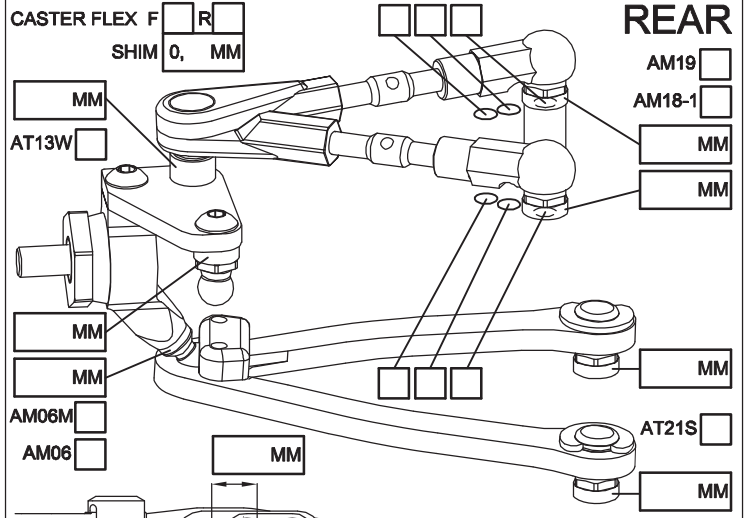

CAMBER ANGLE / ° \_\_\_\_\_  
 CASTER ANGLE / ° \_\_\_\_\_  
 TOE ANGLE / ° \_\_\_\_\_  
 RIDE HEIGHT / MM \_\_\_\_\_  
 DOWNSTOP / MM \_\_\_\_\_  
 UPSTOP / MM \_\_\_\_\_  
 STABILIZER Ø / MM \_\_\_\_\_  
 LOW ARM C04M    
 STEERING ARM STD    
 WHEEL SPACER / MM \_\_\_\_\_  
 REAR DRIVE BALL DIFF  GD3R  GD2   
 DIFF OIL \_\_\_\_\_ DIFF WASHERS \_\_\_\_\_  
 DOGBONE DRIVE ST11  ST12  BB  ST17-1  EVD

**SHOCKS SET**

ROTOR STD    
 SPRING STD  S   
 DAMPER D2.1    
 ACTION SYM.  ASYM.   
 SRS/RHS ARR. I  II

### FRAME FLEX SETTING

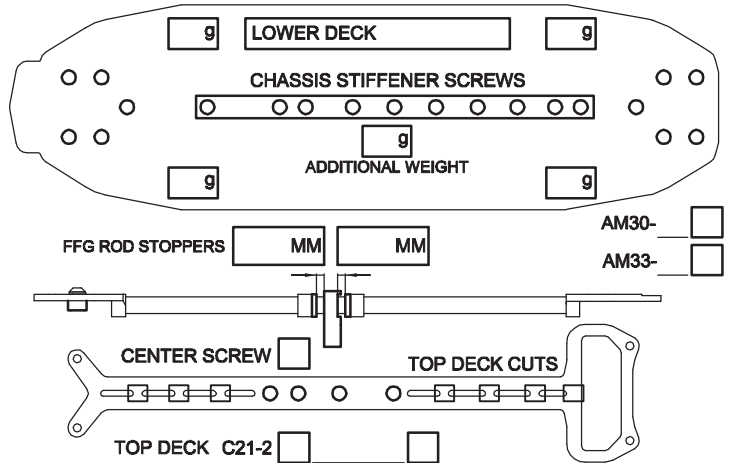

FL	FR	RL	RR	TIRES	FRONT	REAR
FL	FR	RL	RR	BRAND	_____	_____
FL	FR	RL	RR	INSERTS	_____	_____
FL	FR	RL	RR	WHEELS	_____	_____
FL	FR	RL	RR	ADDITIVE	_____	_____

MOTOR MOUNT MODE \_\_\_\_\_ MOTOR \_\_\_\_\_  
 BAT. LAYOUT AM69  F1  F2  SERVO \_\_\_\_\_  
 SD1  SD2  SD3  DRIVE RATIO \_\_\_\_\_ ESC \_\_\_\_\_  
 SPUR \_\_\_\_\_ PINION \_\_\_\_\_ BATTERY \_\_\_\_\_  
 BODY \_\_\_\_\_ RECEIVER \_\_\_\_\_  
 WING \_\_\_\_\_ MOTOR OFFSET / MM \_\_\_\_\_

BEST LAPTIME \_\_\_\_\_ QUALIF. / FINAL POSITION \_\_\_\_\_ /

ESC SETTING \_\_\_\_\_  
 COMMENTS / IMPRESSIONS \_\_\_\_\_  
 \_\_\_\_\_  
 \_\_\_\_\_  
 CONTACT \_\_\_\_\_

