

NAME *Jonathan Porta*  
 COUNTRY \_\_\_\_\_  
 RACE \_\_\_\_\_  
 TRACK *Frontenex 2012*

## SETUP SHEET

DATE \_\_\_\_\_ TEMP.°C AIR / TRACK \_\_\_\_\_ /  
 CARPET  ASPHALT   
 TRACK CONDITION TECHNICAL  MIXED  FAST   
 TRACTION LOW  MEDIUM  HIGH

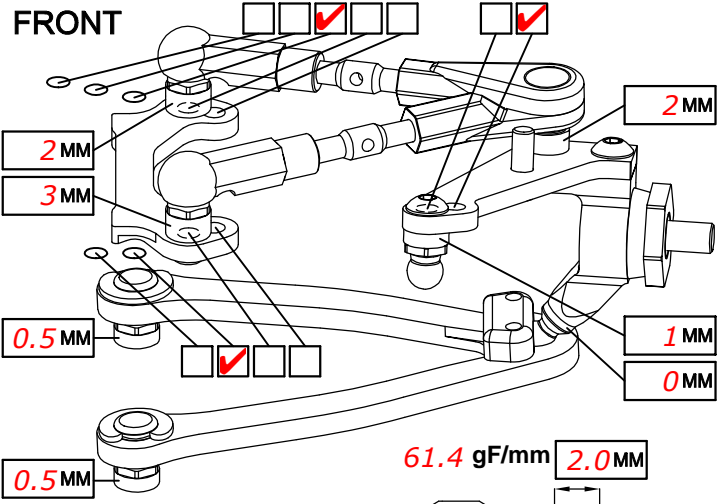

CAMBER ANGLE / ° *1.5*  
 CASTER ANGLE / ° *3*  
 TOE ANGLE / ° *2*  
 RIDE HEIGHT / MM *5.3*  
 DOWNSTOP / MM *5.5*  
 UPSTOP / MM *none*  
 STABILIZER Ø / MM *1.3*  
 LOW ARM STD  \_\_\_\_\_  
 STEERING ARM STD  \_\_\_\_\_  
 WHEEL SPACER / MM \_\_\_\_\_  
 FRONT DRIVE BALL DIFF  GEAR DIFF  SPOOL  ONE-WAY   
 DIFF SET LOOSE  MEDIUM  TIGHT  OIL  # \_\_\_\_\_  
 DOGBONE DRIVE BUSHING  C-DRIVE  BB  EVD

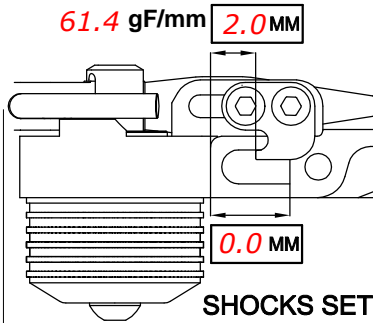

**SHOCKS SET**  
 SPRING STD  \_\_\_\_\_  
 DAMPER STD  \_\_\_\_\_  
 ACTION SYM.  ASYM.   
 SRS/RHS ARR. I  II

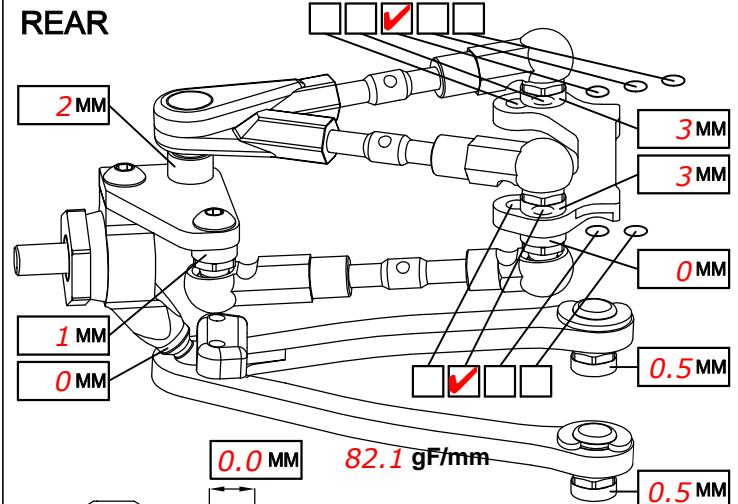

CAMBER ANGLE / ° *2*  
 CASTER ANGLE / ° *0*  
 TOE ANGLE / ° *3*  
 RIDE HEIGHT / MM *5.5*  
 DOWNSTOP / MM *5*  
 UPSTOP / MM *none*  
 STABILIZER Ø / MM *1.2*  
 LOW ARM STD  \_\_\_\_\_  
 STEERING ARM STD  \_\_\_\_\_  
 WHEEL SPACER / MM \_\_\_\_\_  
 REAR DRIVE BALL DIFF  GEAR DIFF   
 DIFF SET LOOSE  MEDIUM  TIGHT  OIL  # *1000*  
 DOGBONE DRIVE BUSHING  C-DRIVE  BB  EVD

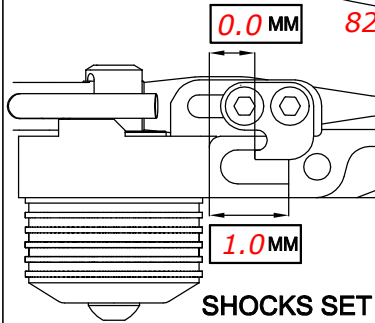

**SHOCKS SET**  
 SPRING STD  \_\_\_\_\_  
 DAMPER STD  \_\_\_\_\_  
 ACTION SYM.  ASYM.   
 SRS/RHS ARR. I  II

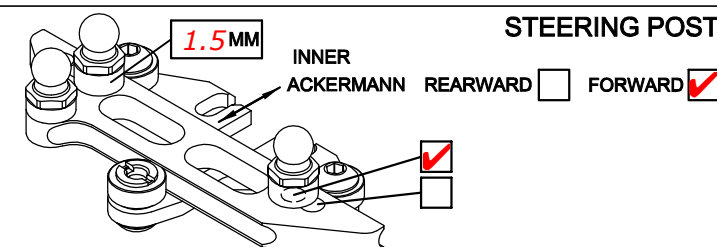
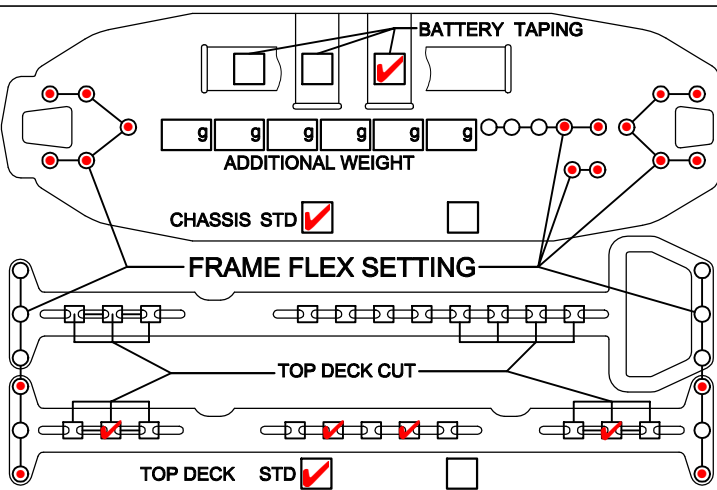

**STEERING POST**  
 INNER ACKERMANN REARWARD  FORWARD

FL	FR	RL	RR	TIRES	FRONT	REAR
				BRAND	<i>Ride 36R</i>	<i>Ride 36R</i>
				INSERTS	<i>SRCCA</i>	<i>SRCCA</i>
				WHEELS	<i>SRCCA</i>	<i>SRCCA</i>
				ADDITIVE	<i>none</i>	<i>none</i>

MOTOR LAYOUT LONG.  TRANS.  MOTOR *TO 10.5*  
 SERVO LAYOUT LEFT  RIGHT  SERVO *2413ICS*  
 ESC LAYOUT LEFT  RIGHT  ESC *Hobbywing 120A 2.1*  
 BAT. LAYOUT R1  R2  F1  F2  BATTERY *CarbonPro 5000*  
 SPUR *90* PINION *37* RECEIVER *R603FS*  
 FINAL DRIVE RATIO *5.06* MOTOR OFFSET / MM *0*  
 BODY *MazdaSpeed* WING *Std*

BEST LAPTIME \_\_\_\_\_ QUALIF. / FINAL POSITION \_\_\_\_\_ /  
 ESC SETTING *Disponible séparément*  
 COMMENTS / IMPRESSIONS \_\_\_\_\_  
 CONTACT \_\_\_\_\_