

NAME \_\_\_\_\_

COUNTRY \_\_\_\_\_

RACE \_\_\_\_\_

TRACK \_\_\_\_\_

DATE \_\_\_\_\_ TEMP.°C AIR / TRACK \_\_\_\_\_ /

CARPET  ASPHALT

TRACK CONDITION TECHNICAL  MIXED  FAST

TRACTION LOW  MEDIUM  HIGH

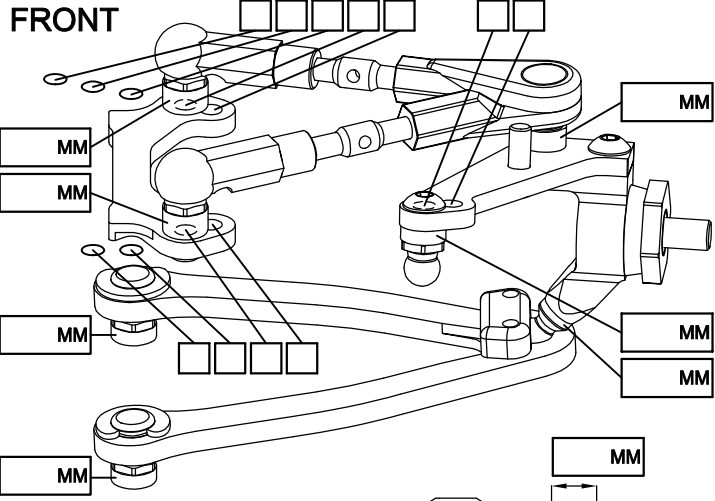

CAMBER ANGLE / ° \_\_\_\_\_

CASTER ANGLE / ° \_\_\_\_\_

TOE ANGLE / ° \_\_\_\_\_

RIDE HEIGHT / MM \_\_\_\_\_

DOWNSTOP / MM \_\_\_\_\_

UPSTOP / MM \_\_\_\_\_

STABILIZER Ø / MM \_\_\_\_\_

LOW ARM STD  \_\_\_\_\_

STEERING ARM STD  \_\_\_\_\_

WHEEL SPACER / MM \_\_\_\_\_

FRONT DRIVE BALL DIFF  GEAR DIFF  SPOOL  ONE-WAY

DIFF SET LOOSE  MEDIUM  TIGHT  OIL  # \_\_\_\_\_

DOGBONE DRIVE BUSHING  C-DRIVE  BB  EVD

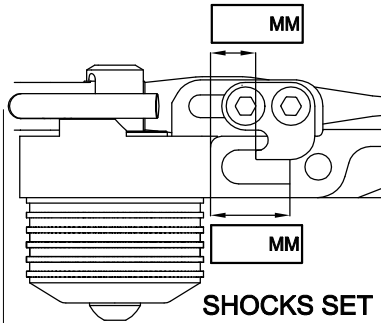

**SHOCKS SET**

SPRING STD  \_\_\_\_\_

DAMPER STD  \_\_\_\_\_

ACTION SYM.  ASYM.

SRS/RHS ARR. I  II

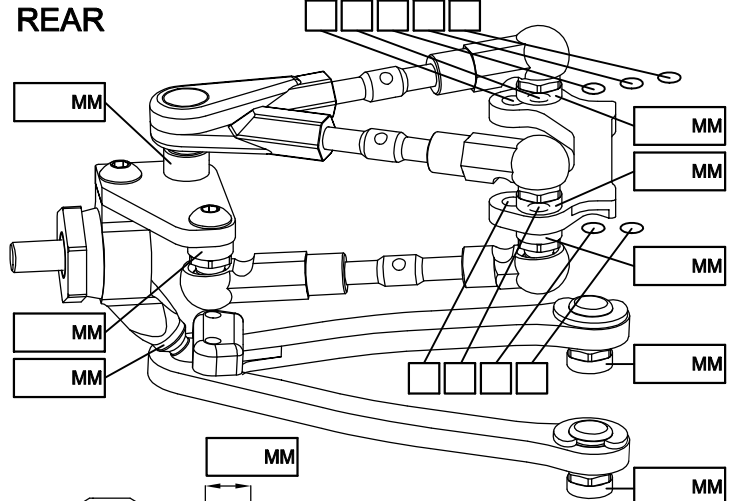

CAMBER ANGLE / ° \_\_\_\_\_

CASTER ANGLE / ° \_\_\_\_\_

TOE ANGLE / ° \_\_\_\_\_

RIDE HEIGHT / MM \_\_\_\_\_

DOWNSTOP / MM \_\_\_\_\_

UPSTOP / MM \_\_\_\_\_

STABILIZER Ø / MM \_\_\_\_\_

LOW ARM STD  \_\_\_\_\_

STEERING ARM STD  \_\_\_\_\_

WHEEL SPACER / MM \_\_\_\_\_

REAR DRIVE BALL DIFF  GEAR DIFF

DIFF SET LOOSE  MEDIUM  TIGHT  OIL  # \_\_\_\_\_

DOGBONE DRIVE BUSHING  C-DRIVE  BB  EVD

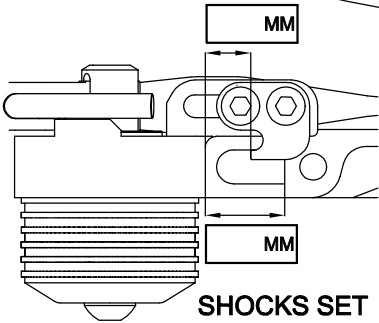

**SHOCKS SET**

SPRING STD  \_\_\_\_\_

DAMPER STD  \_\_\_\_\_

ACTION SYM.  ASYM.

SRS/RHS ARR. I  II

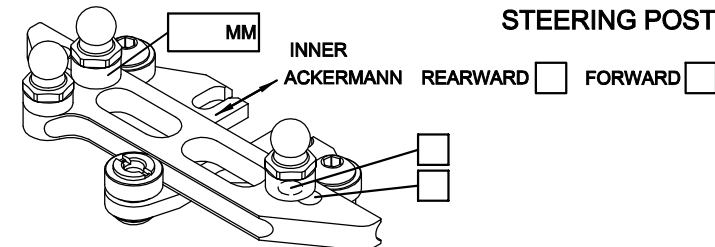
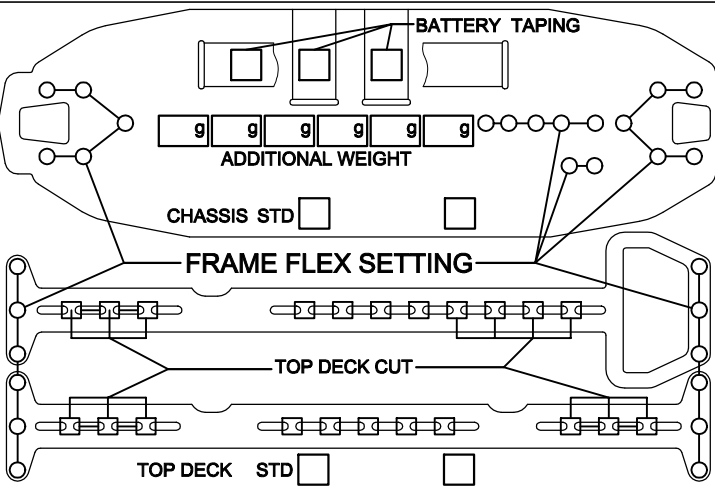

**STEERING POST**

INNER ACKERMANN REARWARD  FORWARD

FL	FR	RL	RR	TIRES	FRONT	REAR
				BRAND		
				INSERTS		
				WHEELS		
				ADDITIVE		

MOTOR LAYOUT LONG.  TRANS.  MOTOR \_\_\_\_\_

SERVO LAYOUT LEFT  RIGHT  SERVO \_\_\_\_\_

ESC LAYOUT LEFT  RIGHT  ESC \_\_\_\_\_

BAT. LAYOUT R1  R2  F1  F2  BATTERY \_\_\_\_\_

SPUR PINION RECEIVER \_\_\_\_\_

FINAL DRIVE RATIO MOTOR OFFSET / MM \_\_\_\_\_

BODY WING \_\_\_\_\_

BEST LAP TIME \_\_\_\_\_ QUALIF. / FINAL POSITION \_\_\_\_\_ /

ESC SETTING \_\_\_\_\_

COMMENTS / IMPRESSIONS \_\_\_\_\_

CONTACT \_\_\_\_\_