

NAME **Gabriele Vignolini**
 COUNTRY **Italy**
 RACE **C.I. UISP - Gara 1**
 TRACK **Scandiano**

SETUP SHEET

DATE **18/03/2012** TEMP.°C AIR / TRACK /
 TRACK CONDITION TECHNICAL CARPET ASPHALT
 MIXED FAST
 TRACTION LOW MEDIUM HIGH

FRONT

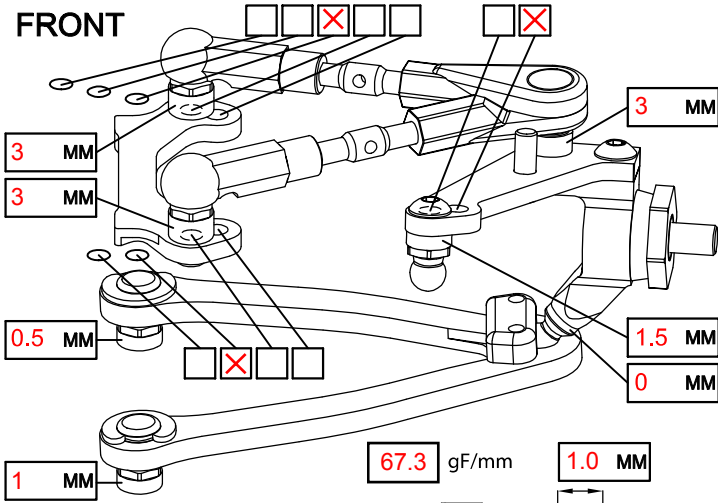

CAMBER ANGLE / ° **-1.5**
 CASTER ANGLE / ° **5**
 TOE ANGLE / ° **1**
 RIDE HEIGHT / MM **5.2**
 DOWNSTOP / MM **5.6**
 UPSTOP / MM **max**
 STABILIZER Ø / MM **no**
 LOW ARM STD
 STEERING ARM STD
 WHEEL SPACER / MM
 FRONT DRIVE BALL DIFF GEAR DIFF SPOOL ONE-WAY
 DIFF SET LOOSE MEDIUM TIGHT OIL #
 DOGBONE DRIVE BUSHING C-DRIVE BB EVD

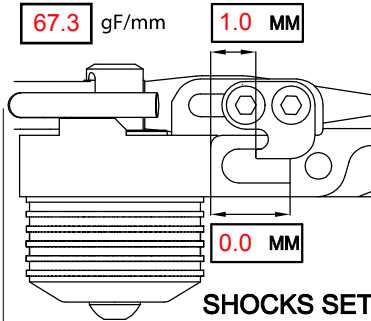

SHOCKS SET

SPRING STD
 DAMPER STD
 ACTION SYM. ASYM.
 SRS/RHS ARR. I II

REAR

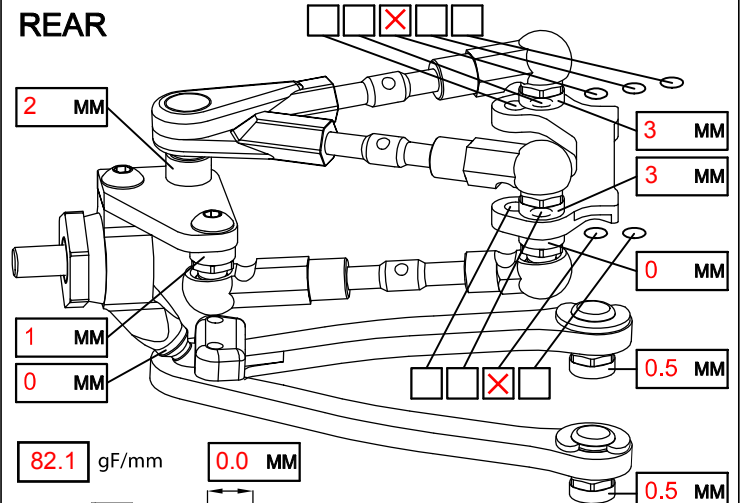

CAMBER ANGLE / ° **-1.5**
 CASTER ANGLE / ° **5 (2 mm)**
 TOE ANGLE / ° **-3**
 RIDE HEIGHT / MM **5.2**
 DOWNSTOP / MM **5.6**
 UPSTOP / MM **max**
 STABILIZER Ø / MM **no**
 LOW ARM STD
 STEERING ARM STD
 WHEEL SPACER / MM
 REAR DRIVE BALL DIFF GEAR DIFF
 DIFF SET LOOSE MEDIUM TIGHT OIL # **100wt**
 DOGBONE DRIVE BUSHING C-DRIVE BB EVD

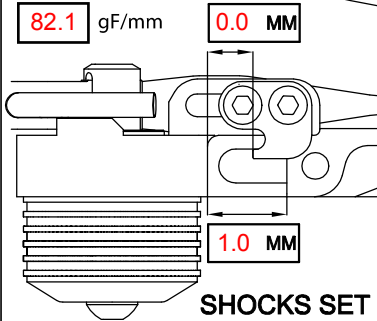

SHOCKS SET

SPRING STD
 DAMPER STD
 ACTION SYM. ASYM.
 SRS/RHS ARR. I II

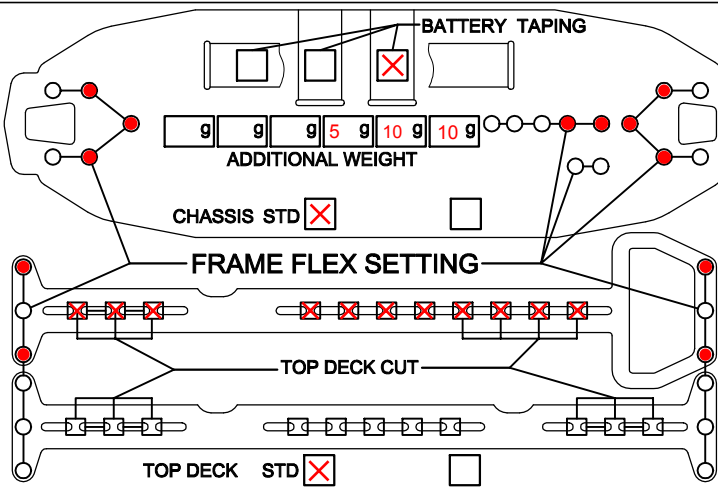

STEERING POST

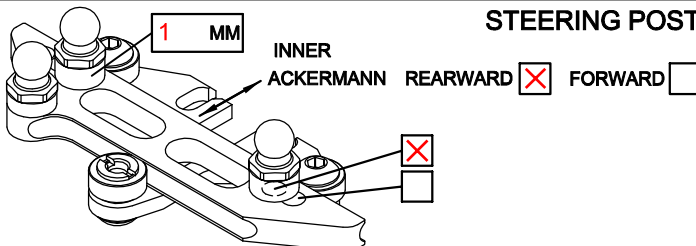

FL	FR	RL	RR	TIRES	FRONT	REAR
				BRAND	LRP CPX	LRP CPX
				INSERTS	std	std
				WHEELS	std	std
				ADDITIVE	AME	CS

MOTOR LAYOUT LONG. TRANS. MOTOR **SP V3 13.5**
 SERVO LAYOUT LEFT RIGHT SERVO **GM**
 ESC LAYOUT LEFT RIGHT ESC **SP Cirtix**
 BAT. LAYOUT R1 R2 F1 F2 BATTERY **Orca**
 SPUR **89** PINION **40** RECEIVER **Sanwa**
 FINAL DRIVE RATIO **4.63** MOTOR OFFSET / MM
 BODY **TCR** WING **std**

BEST LAP TIME **14"980** QUALIF. / FINAL POSITION **6** / **3**
 ESC SETTING
 COMMENTS / IMPRESSIONS
 CONTACT realdamon@libero.it