

NAME \_\_\_\_\_  
 COUNTRY \_\_\_\_\_  
 RACE \_\_\_\_\_  
 TRACK \_\_\_\_\_

## SETUP SHEET

DATE \_\_\_\_\_ TEMP.°C AIR / TRACK \_\_\_\_\_ / \_\_\_\_\_  
 TRACK CONDITION TECHNICAL  MIXED  FAST   
 TRACTION LOW  MEDIUM  HIGH

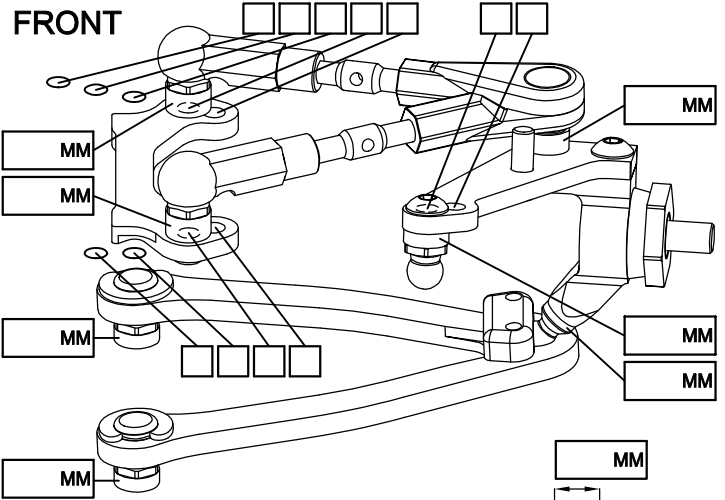

CAMBER ANGLE / ° \_\_\_\_\_  
 CASTER ANGLE / ° \_\_\_\_\_  
 TOE ANGLE / ° \_\_\_\_\_  
 RIDE HEIGHT / MM \_\_\_\_\_  
 DOWNSTOP / MM \_\_\_\_\_  
 UPSTOP / MM \_\_\_\_\_  
 STABILIZER Ø / MM \_\_\_\_\_  
 LOW ARM STD  \_\_\_\_\_  
 STEERING ARM STD  \_\_\_\_\_  
 WHEEL SPACER / MM \_\_\_\_\_  
 FRONT DRIVE BALL DIFF  GEAR DIFF  SPOOL  ONE-WAY   
 DIFF SET LOOSE  MEDIUM  TIGHT  OIL  # \_\_\_\_\_  
 DOGBONE DRIVE BUSHING  C-DRIVE  BB  EVD

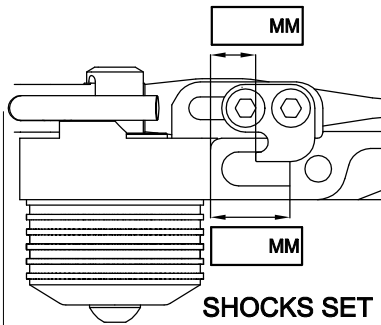

**SHOCKS SET**

SPRING STD  \_\_\_\_\_  
 DAMPER STD  \_\_\_\_\_  
 ACTION SYM.  ASYM.   
 SRS/RHS ARR. I  II

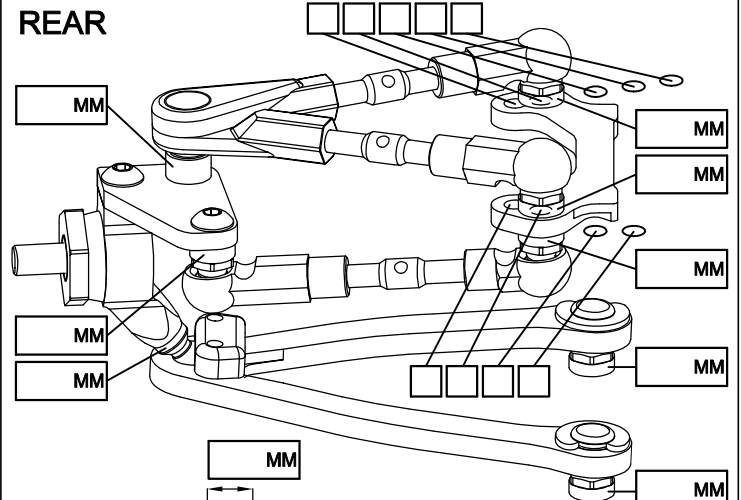

CAMBER ANGLE / ° \_\_\_\_\_  
 CASTER ANGLE / ° \_\_\_\_\_  
 TOE ANGLE / ° \_\_\_\_\_  
 RIDE HEIGHT / MM \_\_\_\_\_  
 DOWNSTOP / MM \_\_\_\_\_  
 UPSTOP / MM \_\_\_\_\_  
 STABILIZER Ø / MM \_\_\_\_\_  
 LOW ARM STD  \_\_\_\_\_  
 STEERING ARM STD  \_\_\_\_\_  
 WHEEL SPACER / MM \_\_\_\_\_  
 REAR DRIVE BALL DIFF  GEAR DIFF   
 DIFF SET LOOSE  MEDIUM  TIGHT  OIL  # \_\_\_\_\_  
 DOGBONE DRIVE BUSHING  C-DRIVE  BB  EVD

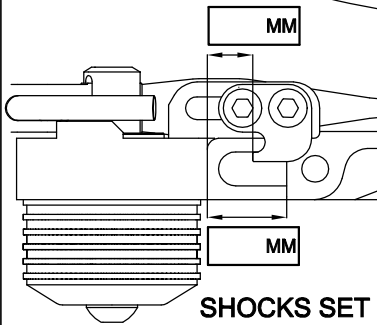

**SHOCKS SET**

SPRING STD  \_\_\_\_\_  
 DAMPER STD  \_\_\_\_\_  
 ACTION SYM.  ASYM.   
 SRS/RHS ARR. I  II

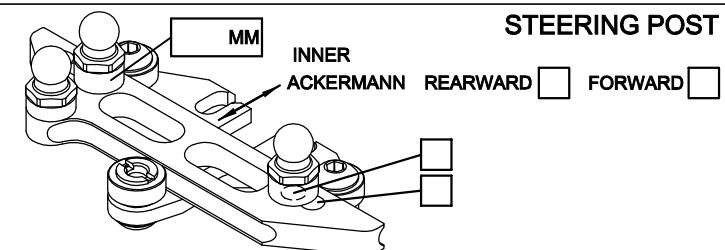
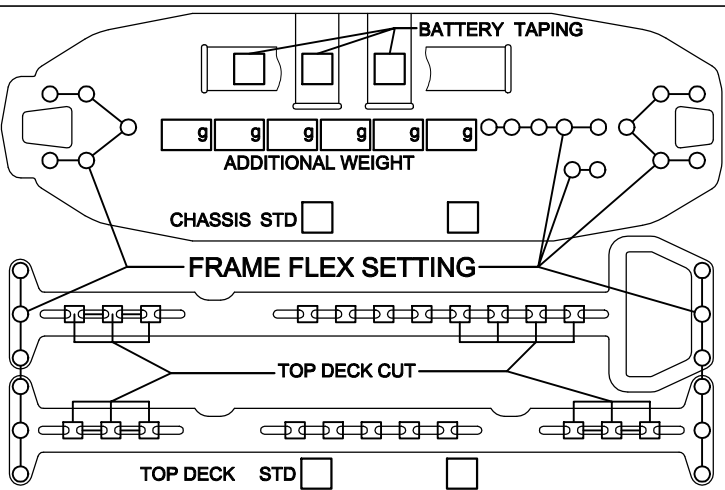

FL	FR	RL	RR	TIRES	FRONT	REAR
				BRAND		
				INSERTS		
				WHEELS		
				ADDITIVE		

MOTOR LAYOUT LONG.  TRANS.  MOTOR \_\_\_\_\_  
 SERVO LAYOUT LEFT  RIGHT  SERVO \_\_\_\_\_  
 ESC LAYOUT LEFT  RIGHT  ESC \_\_\_\_\_  
 BAT. LAYOUT R1  R2  F1  F2  BATTERY \_\_\_\_\_  
 SPUR PINION RECEIVER \_\_\_\_\_  
 FINAL DRIVE RATIO MOTOR OFFSET / MM \_\_\_\_\_  
 BODY WING \_\_\_\_\_

BEST LAP TIME \_\_\_\_\_ QUALIF. / FINAL POSITION \_\_\_\_\_ / \_\_\_\_\_  
 ESC SETTING \_\_\_\_\_  
 COMMENTS / IMPRESSIONS \_\_\_\_\_  
 \_\_\_\_\_  
 \_\_\_\_\_  
 CONTACT \_\_\_\_\_