

NAME **Larry Fairtrace**
 COUNTRY **USA**
 RACE **Halloween Classic**
 TRACK **The Gate**

DATE **27 Oct 2013** TEMP. °C AIR / TRACK °C / °C
 TRACK CONDITION TECHNICAL MIXED FAST
 TRACTION LOW MEDIUM HIGH

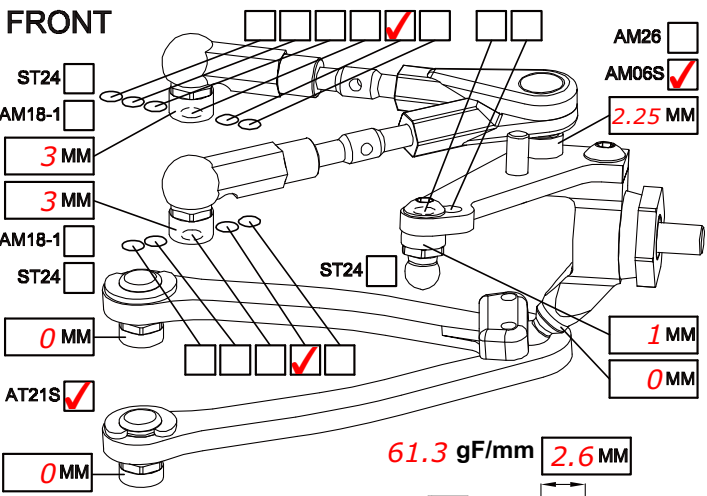

CAMBER ANGLE / ° **1.5**
 CASTER ANGLE / ° **5**
 TOE ANGLE / ° **0.5**
 RIDE HEIGHT / MM **5.5**
 DOWNSTOP / MM **6.25**

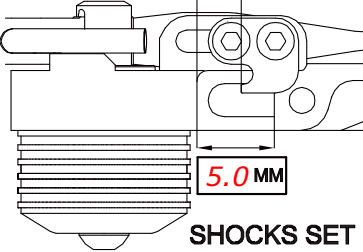

UPSTOP / MM
 STABILIZER Ø / MM **1.1** SPRING STD S
 LOW ARM STD DAMPER #6 #3
 STEERING ARM STD ACTION SYM. ASYM.
 WHEEL SPACER / MM **0** SRS/RHS ARR. I II
 FRONT DRIVE BALL DIFF GEAR DIFF SPOOL ONE-WAY
 DIFF SET LOOSE MEDIUM TIGHT OIL #
 DOGBONE DRIVE BUSHING C-DRIVE BB EVD

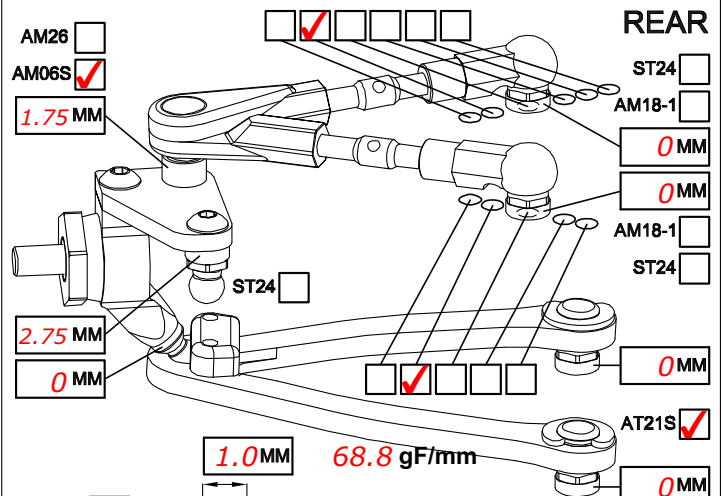

CAMBER ANGLE / ° **2.25**
 CASTER ANGLE / ° **0**
 TOE ANGLE / ° **3.5**
 RIDE HEIGHT / MM **5.5**
 DOWNSTOP / MM **5**

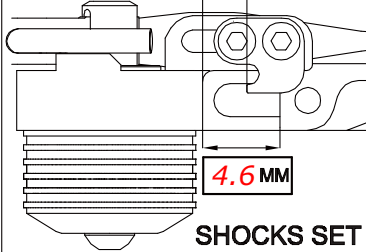

UPSTOP / MM
 STABILIZER Ø / MM **1.1** SPRING STD S
 LOW ARM STD DAMPER #6 #3
 STEERING ARM STD ACTION SYM. ASYM.
 WHEEL SPACER / MM **0** SRS/RHS ARR. I II
 REAR DRIVE BALL DIFF GEAR DIFF
 DIFF SET LOOSE MEDIUM TIGHT OIL # **2K**
 DOGBONE DRIVE BUSHING C-DRIVE BB EVD

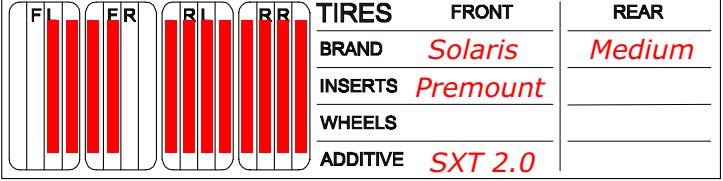
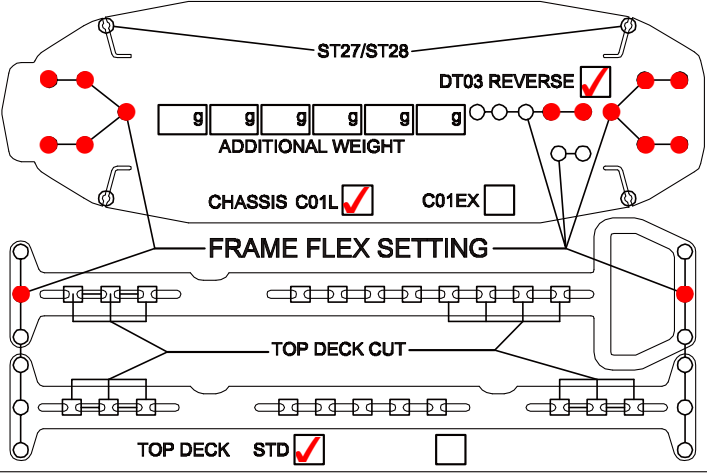

MOTOR LAYOUT LONG TRANS. MOTOR **TeamEAM D3.5**
 SERVO LAYOUT LEFT RIGHT SERVO **Sanwa**
 ESC LAYOUT LEFT RIGHT ESC **ORCA**
 BAT. LAYOUT R1 R2 F1 F2 BATTERY **ORCA**
 SPUR **80** PINION RECEIVER **Sanwa**
 FINAL DRIVE RATIO MOTOR OFFSET / MM
 BODY **LTC LtWt** WING

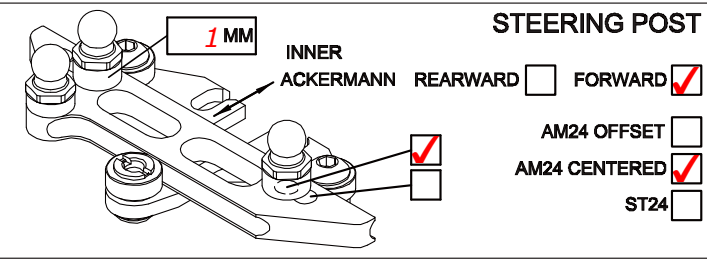

BEST LAPTIME QUALIF. / FINAL POSITION **2 / 3**
 ESC SETTING
 COMMENTS / IMPRESSIONS
AM19 front and rear
 CONTACT