

NAME _____
 COUNTRY _____
 RACE _____
 TRACK _____

DATE _____ TEMP. °C AIR / TRACK _____ /
 TRACK CONDITION TECHNICAL CARPET ASPHALT
 MIXED FAST
 TRACTION LOW MEDIUM HIGH

FRONT

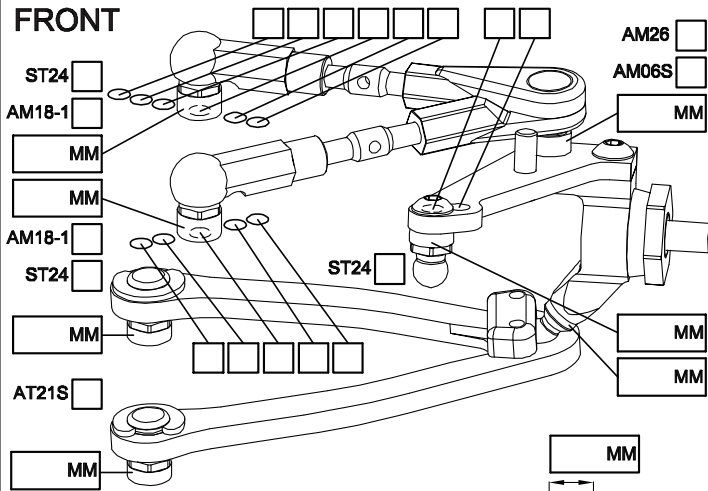

CAMBER ANGLE / ° _____
 CASTER ANGLE / ° _____
 TOE ANGLE / ° _____
 RIDE HEIGHT / MM _____
 DOWNSTOP / MM _____
 UPSTOP / MM _____
 STABILIZER Ø / MM _____
 LOW ARM STD _____
 STEERING ARM STD _____
 WHEEL SPACER / MM _____
 FRONT DRIVE BALL DIFF GEAR DIFF SPOOL ONE-WAY
 DIFF SET LOOSE MEDIUM TIGHT OIL # _____
 DOGBONE DRIVE BUSHING C-DRIVE BB EVD

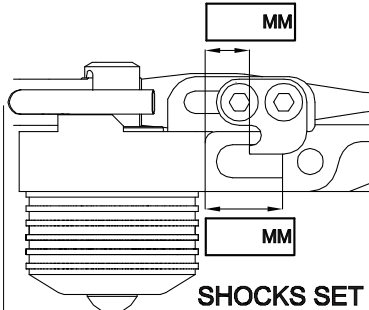

SHOCKS SET
 SPRING STD S
 DAMPER #6 #3
 ACTION SYM. ASYM.
 SRS/RHS ARR. I II

REAR

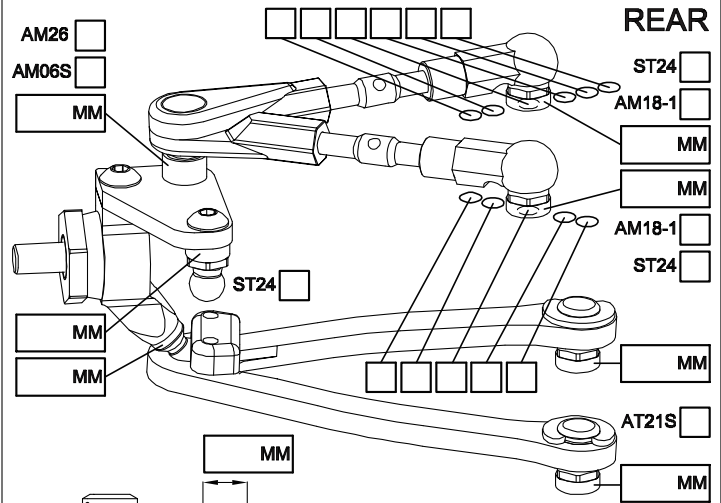

CAMBER ANGLE / ° _____
 CASTER ANGLE / ° _____
 TOE ANGLE / ° _____
 RIDE HEIGHT / MM _____
 DOWNSTOP / MM _____
 UPSTOP / MM _____
 STABILIZER Ø / MM _____
 LOW ARM STD _____
 STEERING ARM STD _____
 WHEEL SPACER / MM _____
 REAR DRIVE BALL DIFF GEAR DIFF
 DIFF SET LOOSE MEDIUM TIGHT OIL # _____
 DOGBONE DRIVE BUSHING C-DRIVE BB EVD

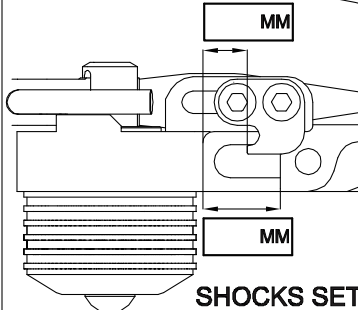

SHOCKS SET
 SPRING STD S
 DAMPER #6 #3
 ACTION SYM. ASYM.
 SRS/RHS ARR. I II

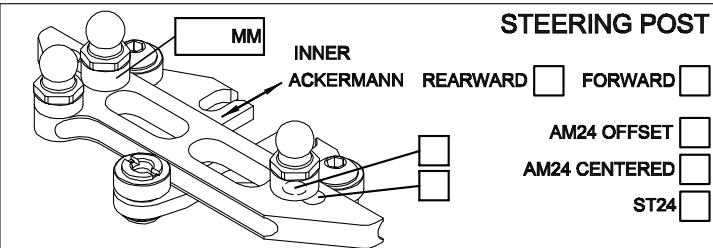
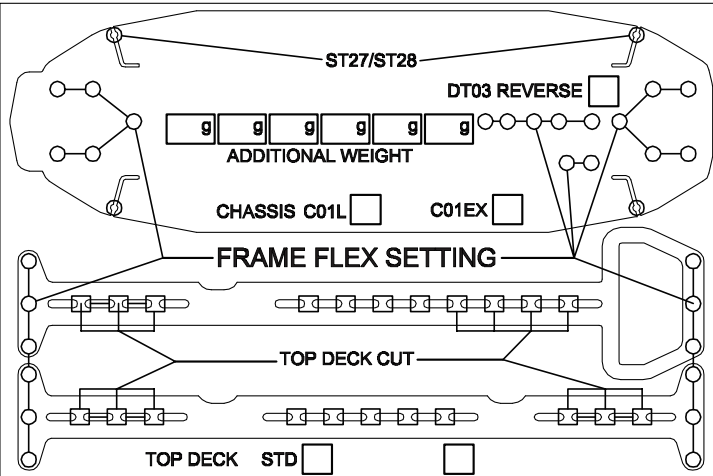

| FL | FR | RL | RR | TIRES | FRONT | REAR |
|----|----|----|----|----------|-------|------|
| | | | | BRAND | | |
| | | | | INSERTS | | |
| | | | | WHEELS | | |
| | | | | ADDITIVE | | |

MOTOR LAYOUT LONG. TRANS. MOTOR _____
 SERVO LAYOUT LEFT RIGHT SERVO _____
 ESC LAYOUT LEFT RIGHT ESC _____
 BAT. LAYOUT R1 R2 F1 F2 BATTERY _____
 SPUR PINION _____ RECEIVER _____
 FINAL DRIVE RATIO _____ MOTOR OFFSET / MM _____
 BODY _____ WING _____

BEST LAP TIME _____ QUALIF. / FINAL POSITION _____ /
 ESC SETTING _____
 COMMENTS / IMPRESSIONS _____

 CONTACT _____