

NAME *Viljami Kutvonen*
 COUNTRY _____
 RACE *FTT Round 4 2013*
 TRACK *Mynämäki, Finland*

DATE *17.03.2013* TEMP. °C AIR / TRACK °C / °C
 TRACK CONDITION TECHNICAL CARPET ASPHALT
 MIXED FAST
 TRACTION LOW MEDIUM HIGH

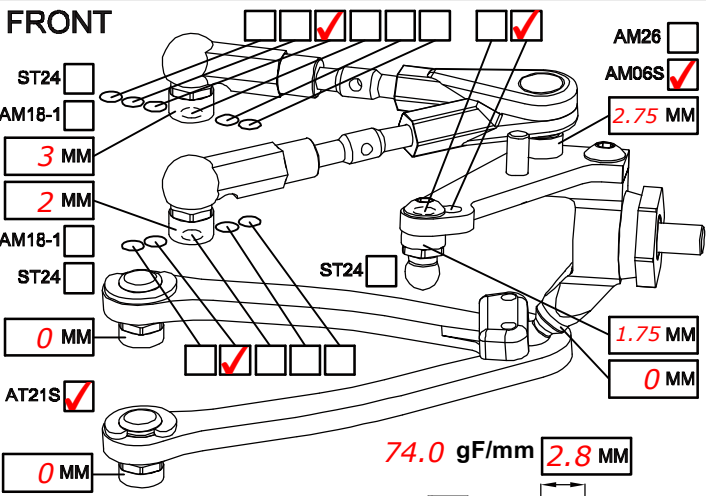

CAMBER ANGLE / ° *1.5*
 CASTER ANGLE / ° *2*
 TOE ANGLE / ° *0.5 out*
 RIDE HEIGHT / MM *4.8*
 DOWNSTOP / MM *6*
 UPSTOP / MM *max*
 STABILIZER Ø / MM *1.2*
 LOW ARM STD
 STEERING ARM STD
 WHEEL SPACER / MM *0*
 FRONT DRIVE BALL DIFF GEAR DIFF SPOOL ONE-WAY
 DIFF SET LOOSE MEDIUM TIGHT OIL # _____
 DOGBONE DRIVE BUSHING C-DRIVE BB EVD

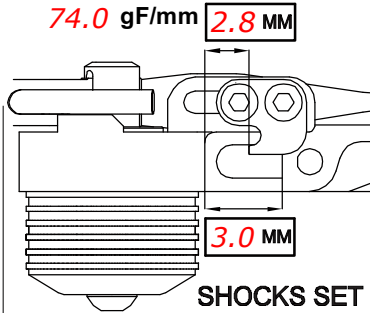

SPRING STD S
 DAMPER #6 #3
 ACTION SYM. ASYM.
 SRS/RHS ARR. I II

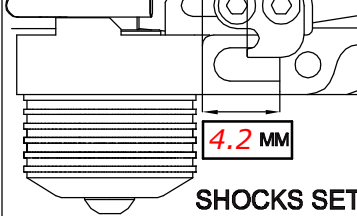
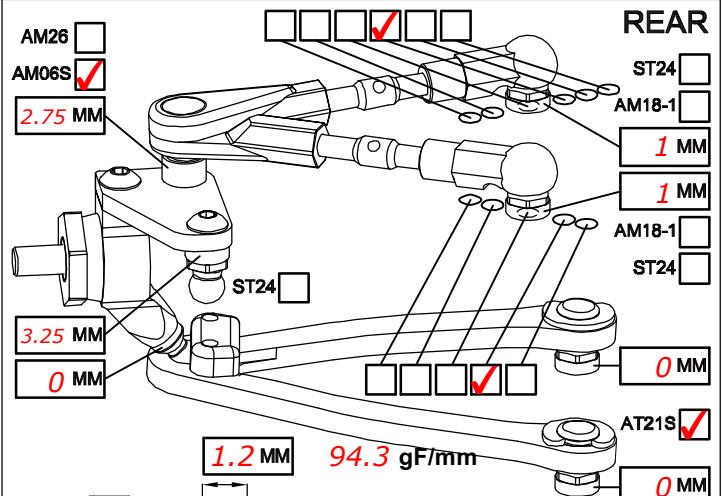

SPRING STD S
 DAMPER #6 #3
 ACTION SYM. ASYM.
 SRS/RHS ARR. I II

CAMBER ANGLE / ° *1.5*
 CASTER ANGLE / ° *0*
 TOE ANGLE / ° *3*
 RIDE HEIGHT / MM *5*
 DOWNSTOP / MM *4.7*
 UPSTOP / MM *max*
 STABILIZER Ø / MM *1.2*
 LOW ARM STD
 STEERING ARM STD
 WHEEL SPACER / MM *0*
 REAR DRIVE BALL DIFF GEAR DIFF
 DIFF SET LOOSE MEDIUM TIGHT OIL # *2000*
 DOGBONE DRIVE BUSHING C-DRIVE BB EVD

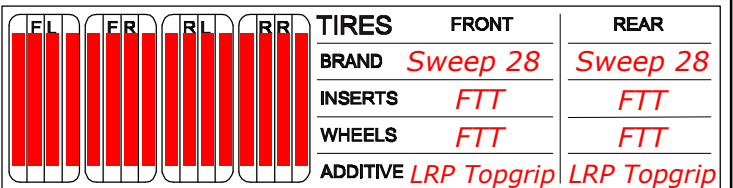
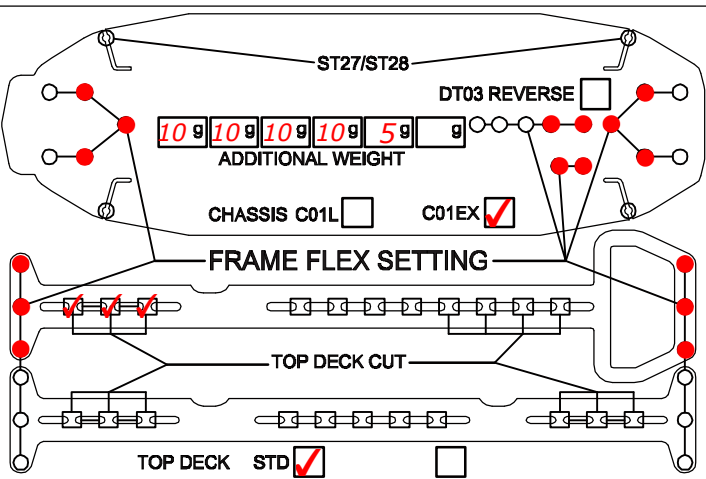

MOTOR LAYOUT LONG. TRANS. MOTOR *LRP X20 4.5T*
 SERVO LAYOUT LEFT RIGHT SERVO *Sanwa SRG-BLS*
 ESC LAYOUT LEFT RIGHT ESC *LRP Flow WorksTeam*
 BAT. LAYOUT R1 R2 F1 F2 BATTERY *LRP 6900 LiPo*
 SPUR *98* PINION *22* RECEIVER *Sanwa 451R*
 FINAL DRIVE RATIO _____ MOTOR OFFSET / MM _____
 BODY *Protoform Speed 6 LW* WING *MR33*

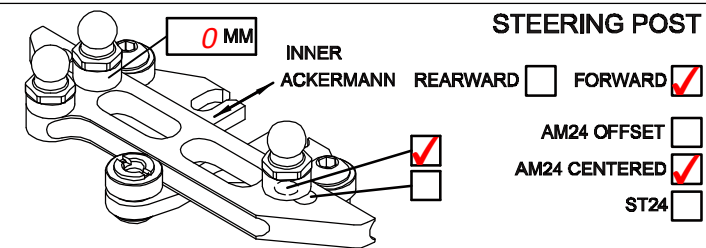

BEST LAPTIME _____ QUALIF. / FINAL POSITION _____ / _____
 ESC SETTING _____
 COMMENTS / IMPRESSIONS *DT03 in reverse position*
Shims are actual shims amount.
 CONTACT _____