

NAME _____

COUNTRY _____

RACE _____

TRACK _____

DATE _____ TEMP. °C AIR / TRACK _____ /

TRACK CONDITION TECHNICAL MIXED FAST

TRACTION LOW MEDIUM HIGH

FRONT

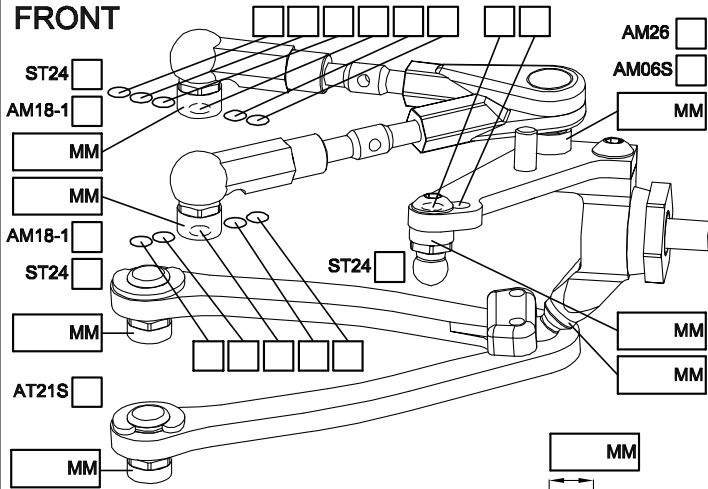

CAMBER ANGLE / ° _____

CASTER ANGLE / ° _____

TOE ANGLE / ° _____

RIDE HEIGHT / MM _____

DOWNSTOP / MM _____

UPSTOP / MM _____

STABILIZER Ø / MM _____

LOW ARM STD _____

STEERING ARM STD _____

WHEEL SPACER / MM _____

FRONT DRIVE BALL DIFF GEAR DIFF SPOOL ONE-WAY

DIFF SET LOOSE MEDIUM TIGHT OIL # _____

DOG BONE DRIVE BUSHING C-DRIVE BB EVD

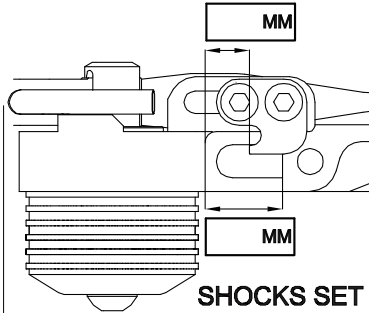

SPRING STD S

DAMPER #6 #3

ACTION SYM. ASYM.

SRS/RHS ARR. I II

REAR

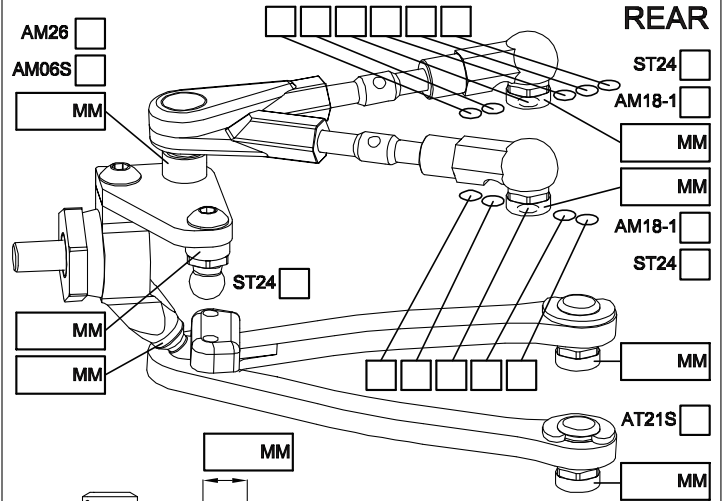

CAMBER ANGLE / ° _____

CASTER ANGLE / ° _____

TOE ANGLE / ° _____

RIDE HEIGHT / MM _____

DOWNSTOP / MM _____

UPSTOP / MM _____

STABILIZER Ø / MM _____

LOW ARM STD _____

STEERING ARM STD _____

WHEEL SPACER / MM _____

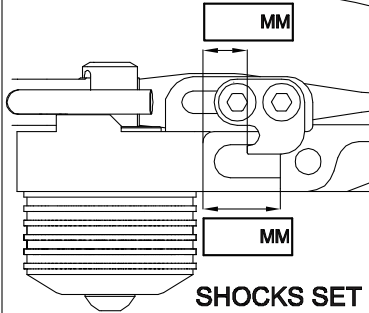

SPRING STD S

DAMPER #6 #3

ACTION SYM. ASYM.

SRS/RHS ARR. I II

REAR DRIVE BALL DIFF GEAR DIFF

DIFF SET LOOSE MEDIUM TIGHT OIL # _____

DOG BONE DRIVE BUSHING C-DRIVE BB EVD

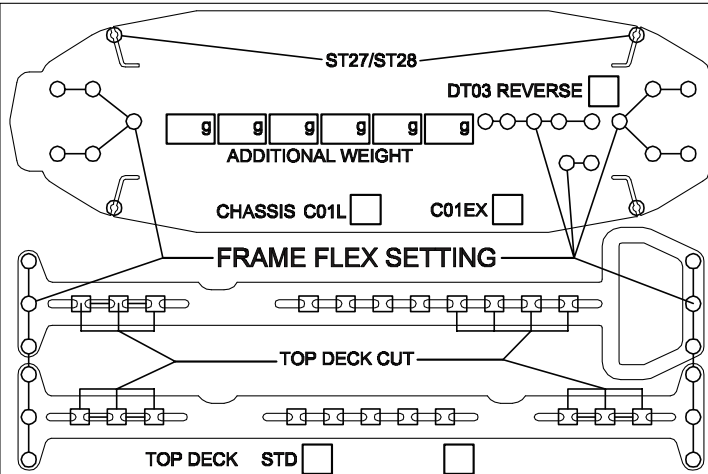

FL	FR	RL	RR	TIRES	FRONT	REAR
				BRAND		
				INSERTS		
				WHEELS		
				ADDITIVE		

MOTOR LAYOUT LONG. TRANS. MOTOR _____

SERVO LAYOUT LEFT RIGHT SERVO _____

ESC LAYOUT LEFT RIGHT ESC _____

BAT. LAYOUT R1 R2 F1 F2 BATTERY _____

SPUR _____ PINION _____ RECEIVER _____

FINAL DRIVE RATIO _____ MOTOR OFFSET / MM _____

BODY _____ WING _____

STEERING POST

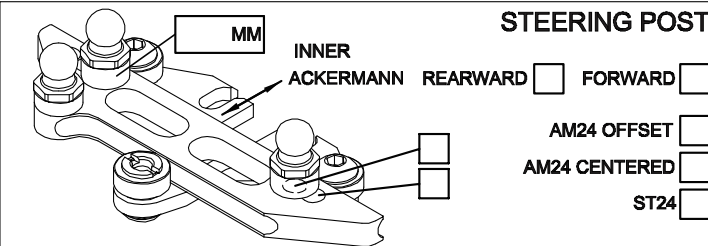

BEST LAP TIME _____ QUALIF. / FINAL POSITION _____ /

ESC SETTING _____

COMMENTS / IMPRESSIONS _____

CONTACT _____