

NAME _____
 COUNTRY _____
 RACE _____
 TRACK _____

DATE _____ TEMP. °C AIR / TRACK _____ /
 TRACK CONDITION TECHNICAL MIXED FAST
 TRACTION LOW MEDIUM HIGH

FRONT

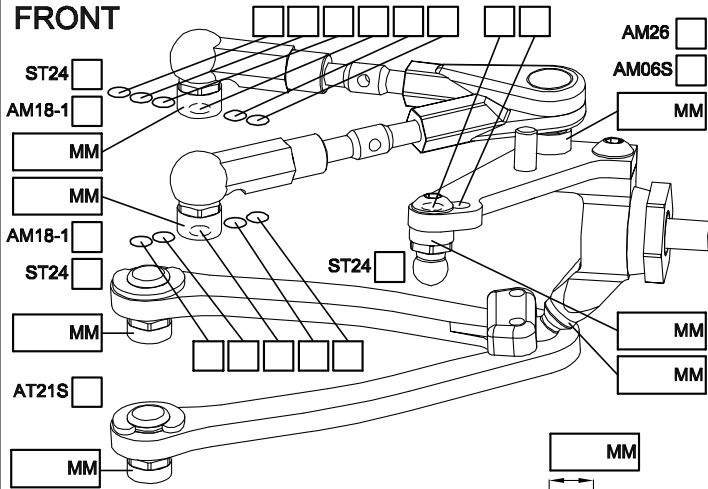

CAMBER ANGLE / ° _____

CASTER ANGLE / ° _____

TOE ANGLE / ° _____

RIDE HEIGHT / MM _____

DOWNSTOP / MM _____

UPSTOP / MM _____

STABILIZER Ø / MM _____

LOW ARM STD _____

STEERING ARM STD _____

WHEEL SPACER / MM _____

FRONT DRIVE BALL DIFF GEAR DIFF SPOOL ONE-WAY

DIFF SET LOOSE MEDIUM TIGHT OIL # _____

DOGBOONE DRIVE BUSHING C-DRIVE BB EVD

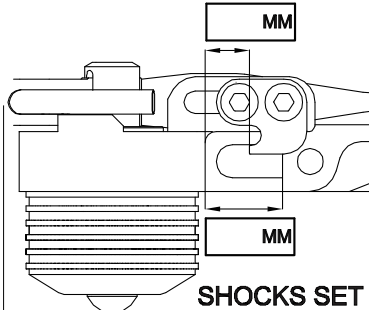

SPRING STD S

DAMPER #6 #3

ACTION SYM. ASYM.

SRS/RHS ARR. I II

REAR

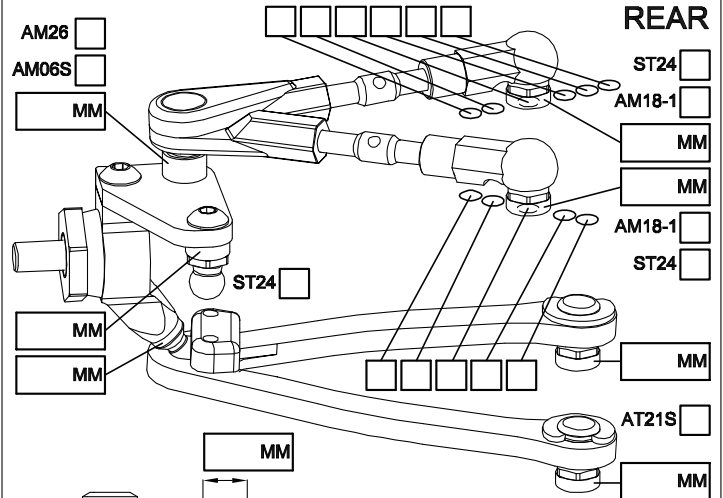

CAMBER ANGLE / ° _____

CASTER ANGLE / ° _____

TOE ANGLE / ° _____

RIDE HEIGHT / MM _____

DOWNSTOP / MM _____

UPSTOP / MM _____

STABILIZER Ø / MM _____

LOW ARM STD _____

STEERING ARM STD _____

WHEEL SPACER / MM _____

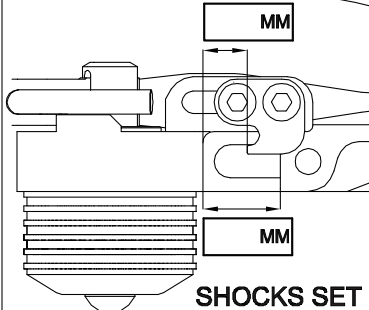

SPRING STD S

DAMPER #6 #3

ACTION SYM. ASYM.

SRS/RHS ARR. I II

REAR DRIVE BALL DIFF GEAR DIFF

DIFF SET LOOSE MEDIUM TIGHT OIL # _____

DOGBOONE DRIVE BUSHING C-DRIVE BB EVD

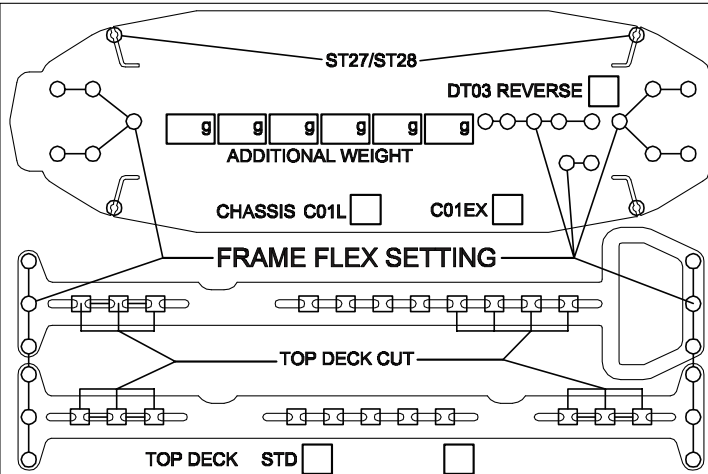

FL	FR	RL	RR	TIRES	FRONT	REAR
				BRAND		
				INSERTS		
				WHEELS		
				ADDITIVE		

MOTOR LAYOUT LONG. TRANS. MOTOR _____
 SERVO LAYOUT LEFT RIGHT SERVO _____
 ESC LAYOUT LEFT RIGHT ESC _____
 BAT. LAYOUT R1 R2 F1 F2 BATTERY _____
 SPUR PINION RECEIVER _____
 FINAL DRIVE RATIO MOTOR OFFSET / MM _____
 BODY WING _____

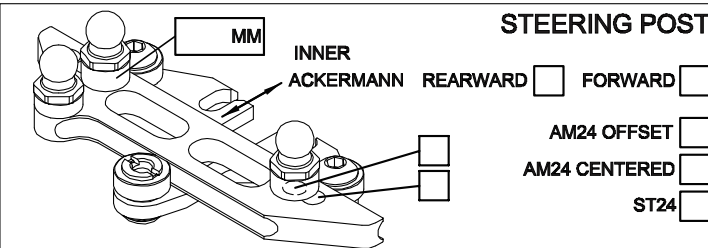

BEST LAPTIME _____ QUALIF. / FINAL POSITION _____ /
 ESC SETTING _____
 COMMENTS / IMPRESSIONS _____

 CONTACT _____