

Front	Alignment	Rear
	Ride Height	
	Camber	
	Caster	N/A
N/A	Rear Hub Toe	
	Toe (Total)	
	Hex Width & Shims	
	Wheelbase	
	Steering Rack Ball & Shims	N/A
	Steering Block Position	N/A
	Steering Block Ball & Shims	N/A

Notes:

Suspension Geometry	
	Shock Position
	Camber Link Position
	Inner Ball & Shims
	Outer Ball & Shims
	Outer Arm Mount Insert
	Outer Mount Shims
	Inner Arm Mount Insert
	Inner Mount Shims
	Droop
	Anti-Roll Bar

Notes:

Shocks	
	Oil
	Piston
	Rebound
	Spring

Notes:

Differentials	
	Type
	Setting
	Cam Position
	Belt Tension Number

Notes:

Tires	
	Type
	Tire Diameter
	Insert & Wheel
	Additive & Amount

Notes:

Chassis	
	Chassis:
	Top Plate:
	Notes:

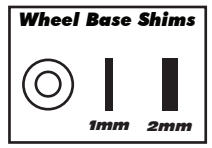
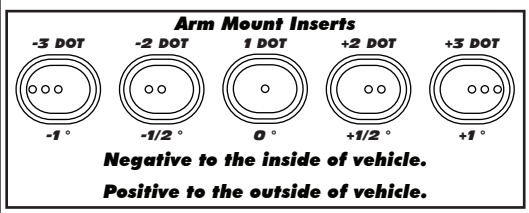
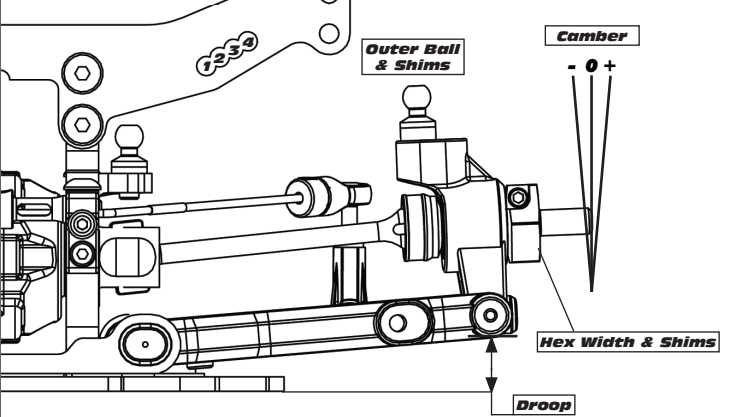
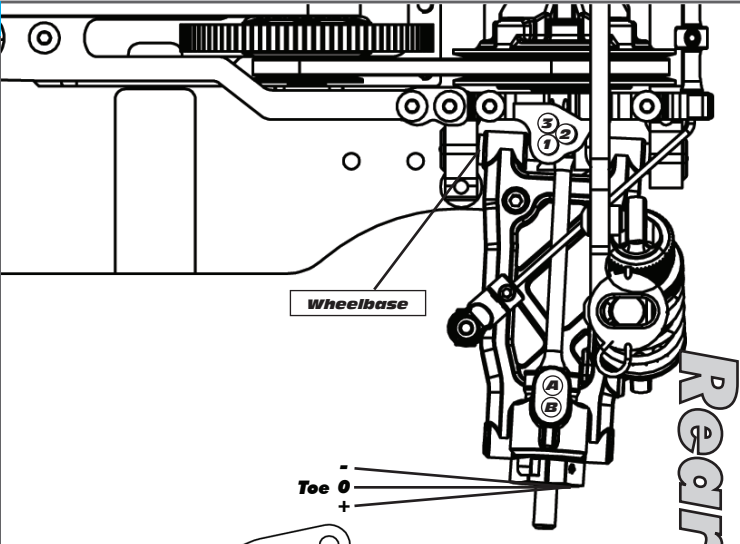

Transmitter		Speed Control	
Turning Circle:		E.S.C. Type:	
Steering Expo:		E.S.C. Settings:	
Brake E.P. :		Software Version:	
Throttle Expo:		Notes:	
<b>Battery Placement</b>		<b>Body &amp; Wing</b>	
Notes:		Notes:	

Notes: \_\_\_\_\_

Notes: \_\_\_\_\_

Notes: \_\_\_\_\_