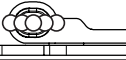
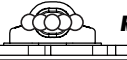
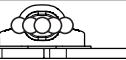
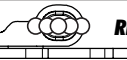

### Track Info

Size:  Small  Medium  Large  XL   
 Surface:  Carpet  Asphalt   
            Indoor  Outdoor   
 Traction:  Low  Medium   
            High  Wet   
 Condition:  Bumpy  Smooth   
 Temperature:  Ambient  Track

### Roll Centers

FF  RF   
 Shim: \_\_\_\_\_ Shim: \_\_\_\_\_  
 FR  RR   
 Shim: \_\_\_\_\_ Shim: \_\_\_\_\_

### Notes

Front	Transmission	Rear
<input type="checkbox"/>	Solid Axle	<input type="checkbox"/>
<input type="checkbox"/>	Gear Diff	<input type="checkbox"/>
	Fluid	
Mass w/Fluid		

Spur: \_\_\_\_\_ Pinion: \_\_\_\_\_ FDR: \_\_\_\_\_

### Notes

Front	Shocks	Rear
	Spring	
	Piston	
	Fluid	
	Rebound	
	Stroke	
	Anti-Roll Bar	

### Notes

### Body & Wing

Body: \_\_\_\_\_ Position: \_\_\_\_\_  
 Wing: \_\_\_\_\_ Position: \_\_\_\_\_

### Notes





### Electronics

Motor: \_\_\_\_\_ Timing: \_\_\_\_\_  
 Battery: \_\_\_\_\_ Mass: \_\_\_\_\_  
 ESC: \_\_\_\_\_ Settings: \_\_\_\_\_  
 Radio: \_\_\_\_\_ Servo: \_\_\_\_\_  
 Turn Circle: \_\_\_\_\_ STR Expo: \_\_\_\_\_  
 Brake Expo: \_\_\_\_\_ THR Expo: \_\_\_\_\_

### Notes

### Tires

Tires: \_\_\_\_\_  
 Insert: \_\_\_\_\_ Wheel: \_\_\_\_\_  
 Tire Diameter (F/R): \_\_\_\_\_  
 Additive (F/R): \_\_\_\_\_  
 Additive Timing: \_\_\_\_\_  

Left FR	Right FR	Left RR	Right RR
			

### Notes

:: Team Associated

Driver: \_\_\_\_\_ Date: \_\_\_\_\_  
 Track: \_\_\_\_\_ Event: \_\_\_\_\_  
 Qualify: \_\_\_\_\_ Best Lap Time: \_\_\_\_\_ Main: \_\_\_\_\_ Finish: \_\_\_\_\_



### Front

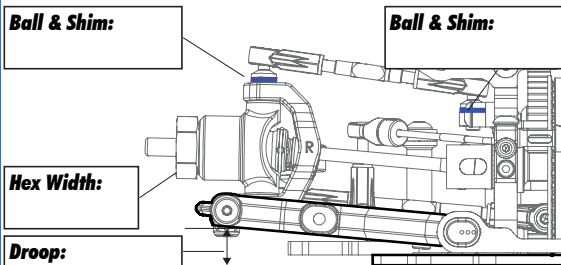
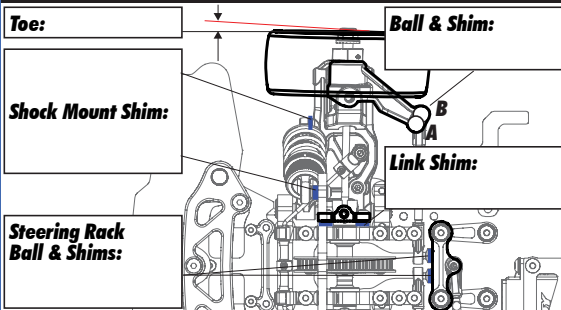
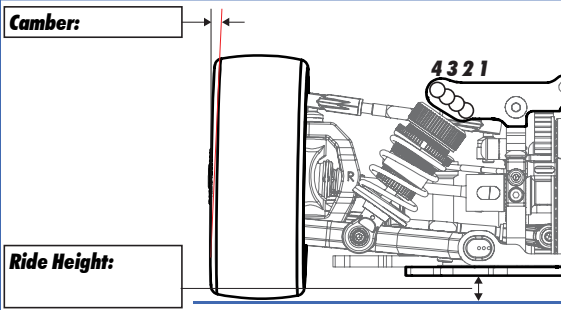

### Notes

### Inline Flex Mount



### Pitch Control System

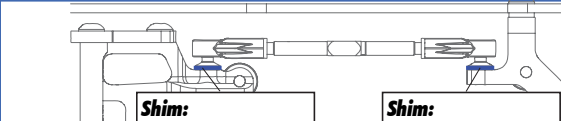

### Notes

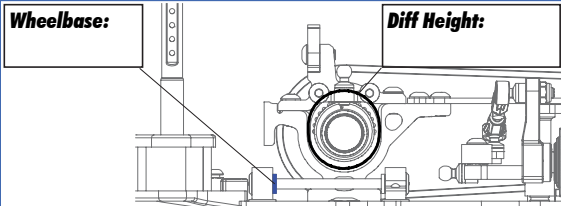

### Notes

### Rear

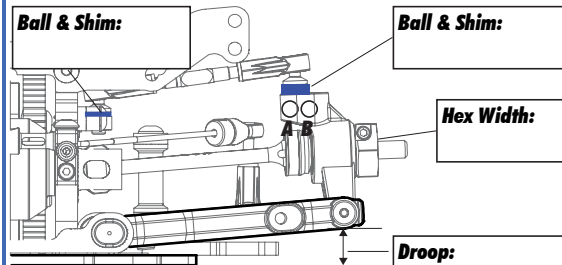
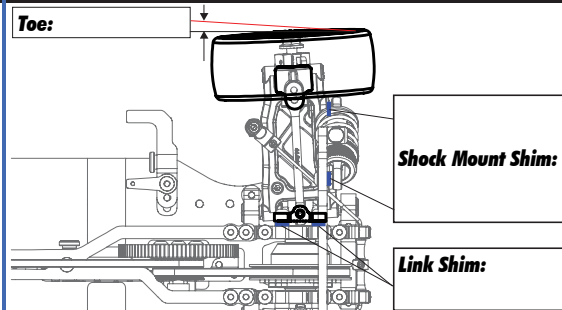
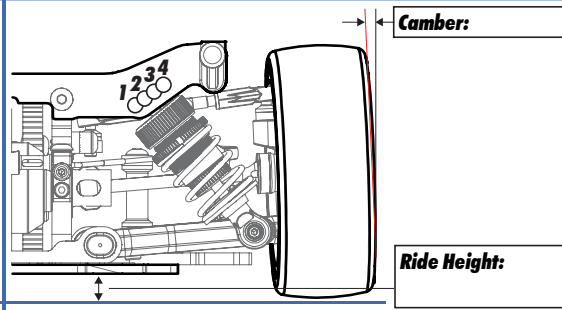

### Notes

### Dynamic Toe Control

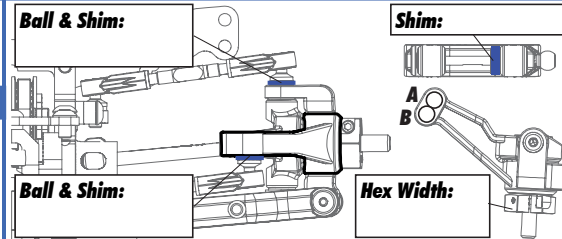

### Notes

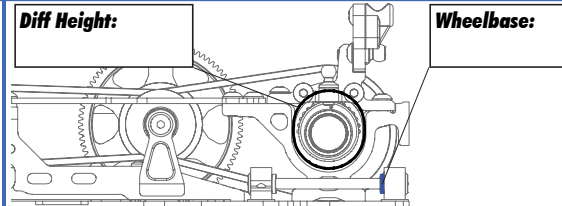

### Notes

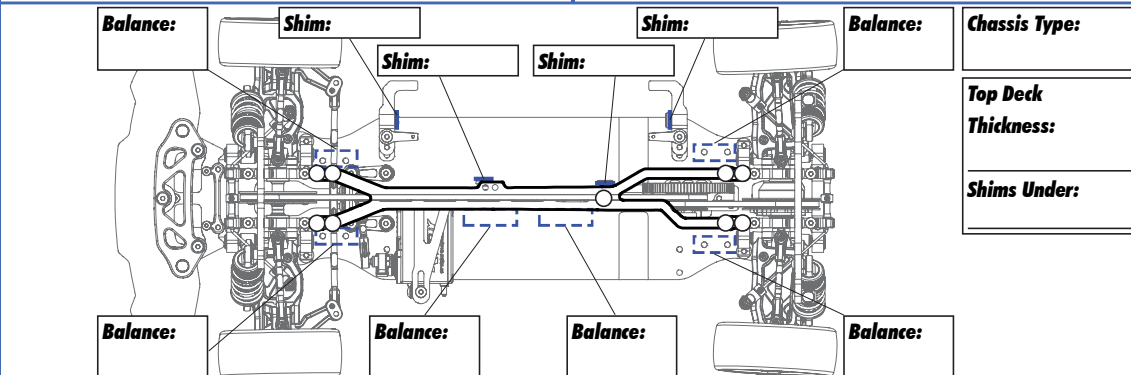

PetitRC: