

Front	Alignment	Rear
	Ride Height	
	Camber	
	Caster	N/A
	Toe	
	Hex Width & Shims	
	Wheelbase	
	Steering Rack Ball & Shims	N/A
	Steering Block Position	N/A
	Steering Block Ball & Shims	N/A

Notes:

Suspension Geometry	
	Shock Position
	Camber Link Position
	Inner Ball & Shims
	Outer Ball & Shims
	Outer Arm Mount Insert
	Outer Mount Shims
	Inner Arm Mount Insert
	Inner Mount Shims
	Droop
	Anti-Roll Bar

Notes:

Shocks	
	Fluid
	Piston
	Rebound
	Spring

Notes:

Differentials	
	Type
	Fluid
	Diff Weight with Fluid
	Cam Position
	Belt Tension Number

Notes:

Tires	
	Type
	Tire Diameter
	Insert & Wheel
	Additive & Amount

Notes:

Chassis	
	Chassis:
	Top Plate:
	Notes:

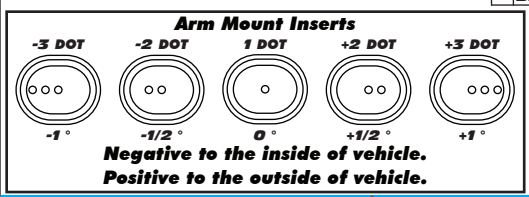
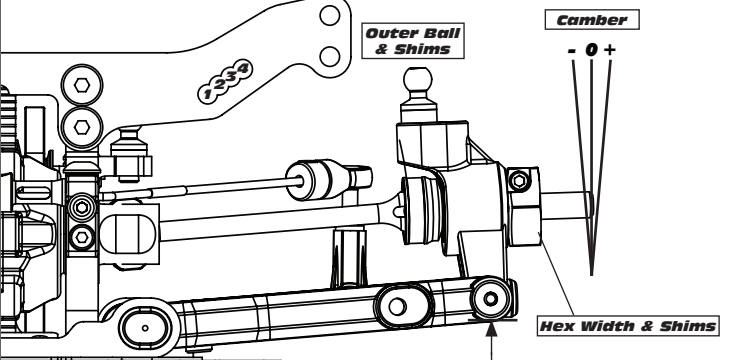
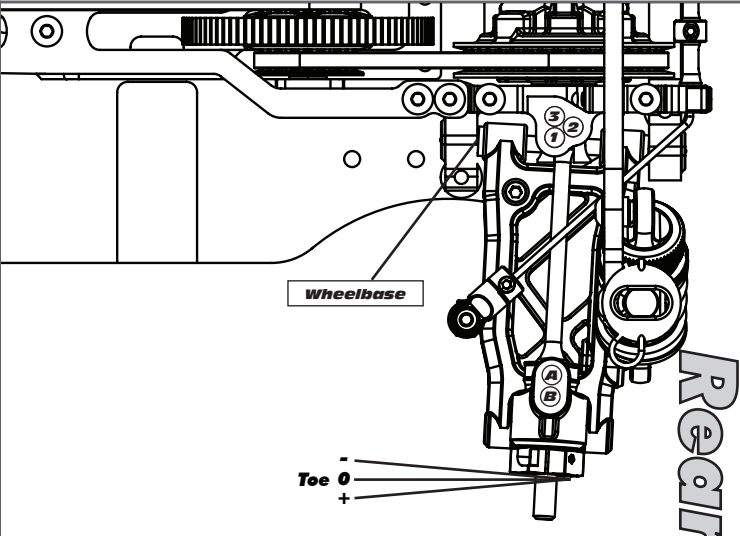

Notes:

Transmitter	
	Turning Circle:
	Steering Expo:
	Brake E.P. :
	Throttle Expo:

Notes:

Speed Control	
	E.S.C. Type:
	E.S.C. Settings:
	Software Version:
	Notes:

Motor	Gearing
	/
Notes:	Notes:

Notes:

Battery	
	Battery Weight:
	Battery Position:
	Notes:

Notes:

Body & Wing	
	Notes: