

| Front | Suspension Geometry | Rear |
|-------|------------------------|------|
| | Outer Arm Mount Insert | |
| | Outer Mount Shims | |
| | Inner Arm Mount Insert | |
| | Inner Mount Shims | |
| | Anti-Roll Bar | |

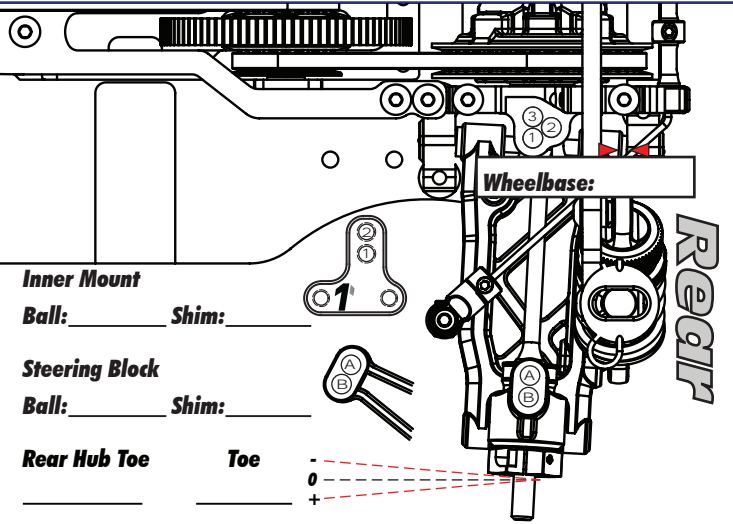

| Shocks | | |
|--------|---------|--|
| | Oil | |
| | Piston | |
| | Rebound | |
| | Spring | |

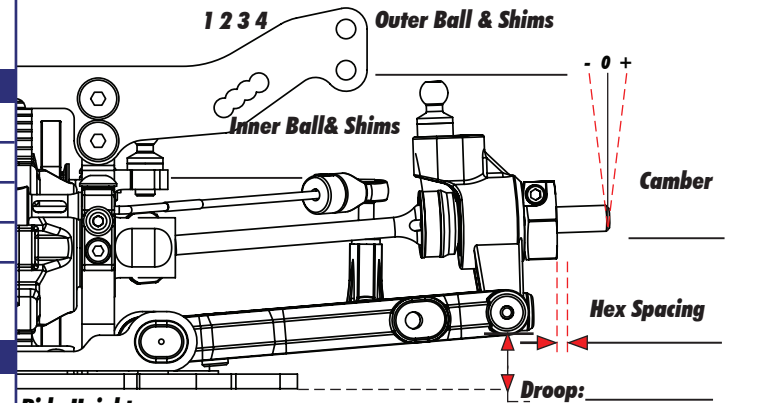

| Differentials | | |
|---------------|---------------------|--|
| | Type | |
| | Setting | |
| | Cam Position | |
| | Belt Tension Number | |

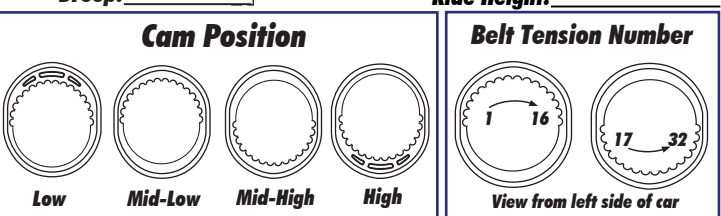
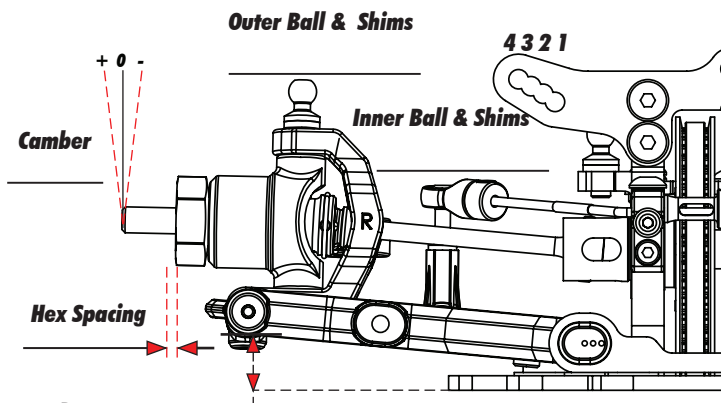
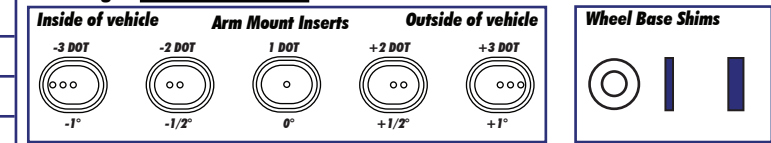

| Chassis | Top Plate |
|---------|-----------|
| | |
| Motor | Gearing |
| | / |

| Tires | | |
|-------|-------------------|--|
| | Type | |
| | Tire Diameter | |
| | Insert & Wheel | |
| | Additive & Amount | |

| Transmitter | Speed Control |
|-----------------------|-------------------------|
| Turning Circle: _____ | E.S.C. Type: _____ |
| Steering Expo: _____ | E.S.C. Settings: _____ |
| Brake E.P. : _____ | Software Version: _____ |
| Throttle Expo: _____ | |
| Battery & Placement | Body & Wing |
| | |