

Front	Suspension Geometry	Rear
	Outer Arm Mount Insert	
	Outer Mount Shims	
	Inner Arm Mount Insert	
	Inner Mount Shims	
	Anti-Roll Bar	

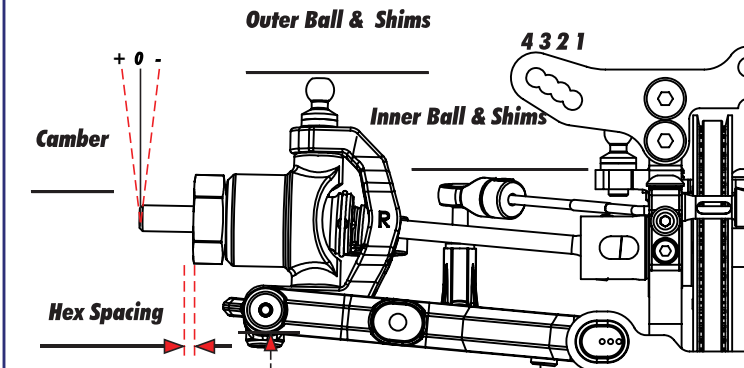

Shocks		
	Oil	
	Piston	
	Rebound	
	Spring	

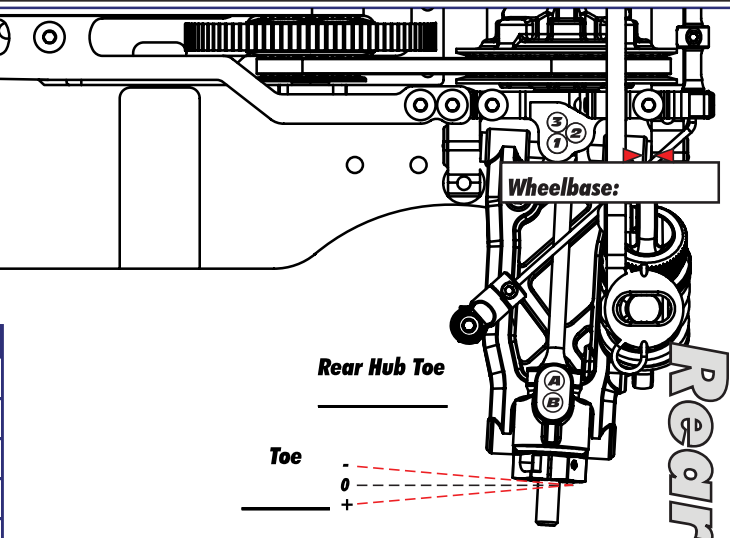
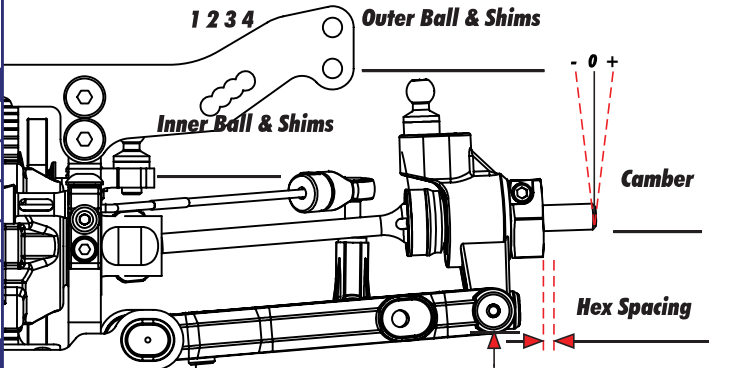

Differentials		
	Type	
	Setting	
	Cam Position	
	Belt Tension Number	

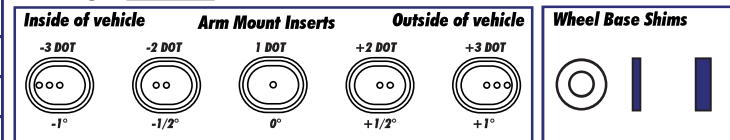
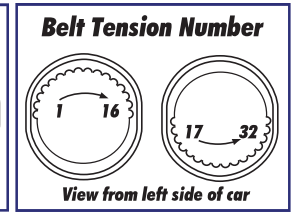
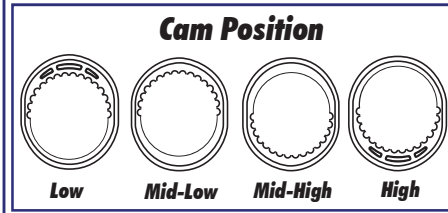

Chassis	Top Plate
Motor	Gearing
	/

Tires		
	Type	
	Tire Diameter	
	Insert & Wheel	
	Additive & Amount	

Transmitter	Speed Control
Turning Circle:	E.S.C. Type:
Steering Expo:	E.S.C. Settings:
Brake E.P.:	Software Version:
Throttle Expo:	
Battery & Placement	Body & Wing