

| Front | Suspension Geometry    | Rear |
|-------|------------------------|------|
|       | Outer Arm Mount Insert |      |
|       | Outer Mount Shims      |      |
|       | Inner Arm Mount Insert |      |
|       | Inner Mount Shims      |      |
|       | Anti-Roll Bar          |      |

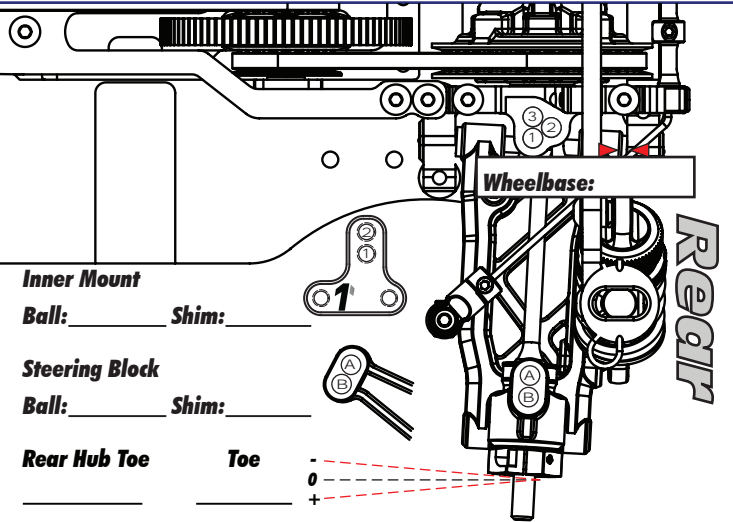

| Shocks |         |  |
|--------|---------|--|
|        | Oil     |  |
|        | Piston  |  |
|        | Rebound |  |
|        | Spring  |  |

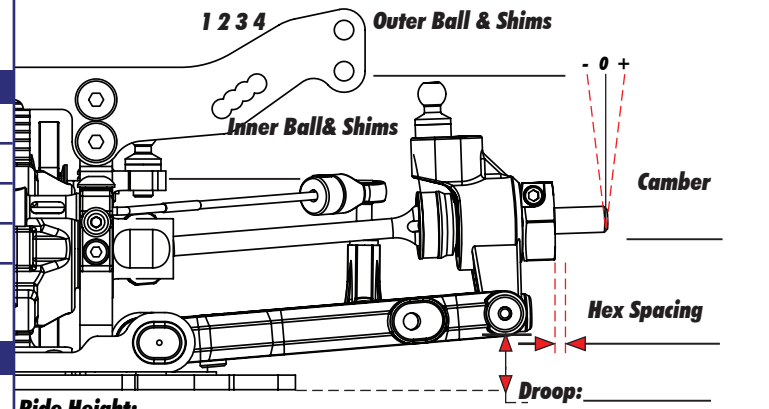

| Differentials |                     |  |
|---------------|---------------------|--|
|               | Type                |  |
|               | Setting             |  |
|               | Cam Position        |  |
|               | Belt Tension Number |  |

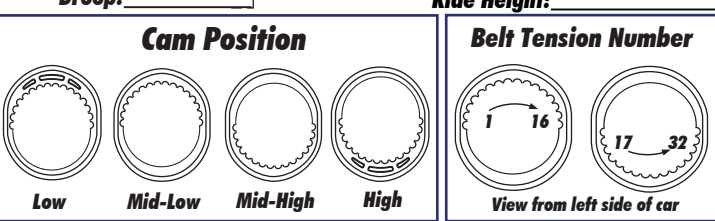
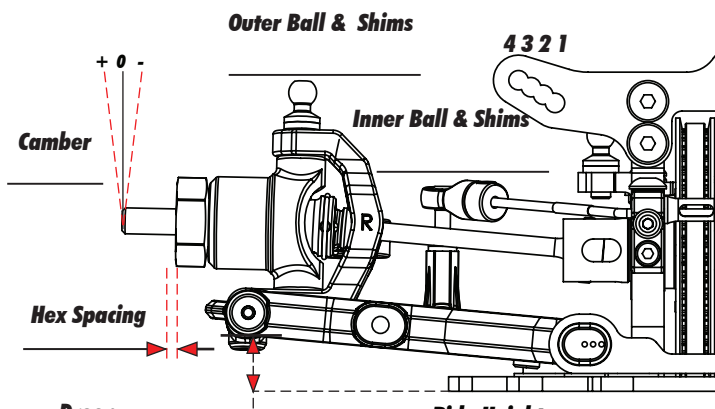
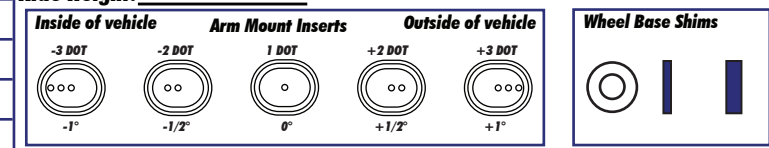

| Chassis | Top Plate |
|---------|-----------|
|         |           |
| Motor   | Gearing   |
|         | /         |

| Tires |                   |  |
|-------|-------------------|--|
|       | Type              |  |
|       | Tire Diameter     |  |
|       | Insert & Wheel    |  |
|       | Additive & Amount |  |

| Transmitter           | Speed Control           |
|-----------------------|-------------------------|
| Turning Circle: _____ | E.S.C. Type: _____      |
| Steering Expo: _____  | E.S.C. Settings: _____  |
| Brake E.P.: _____     | Software Version: _____ |
| Throttle Expo: _____  |                         |
| Battery & Placement   | Body & Wing             |
|                       |                         |