

Setup Sheet for Team Associated's 12R5

Rev. 1

:: Front Suspension

Kingpin Lube: None
 Springs: 0.45mm (AS-4114) Black
 Upper Arm Mounts: 0° 5° 10°
 Camber: -2° Axle Spacers: 1.5 mm
 Bump Steer Spacers: None
 Caster:
 thick thin thin thick thick and thin

 1.80° 3.25° 6.15°
 Ride Height: 1.8 mm
 Notes: Yokomo kingpin used (option)

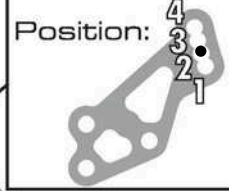
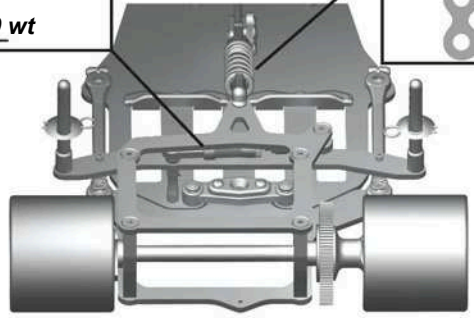
:: Rear Suspension

Side Spring: Black
 T-Plate: N/A
 Ride Height Adjuster: #1
 Ride Height: 2 mm
 Side Shock
 Oil: AE 20 wt
 Center Shock
 Oil: AE 45 wt
 Spring: Gold
 Position: 

 Notes: Rear trackwidth: 172mm

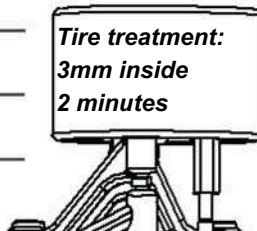
:: Front Tires

Tire: Yokomo L-Rubber Firm
 Diameter: 41 mm
 Wheel Type: Yokomo (SP-1250-3)
 Additive: Paragon FXII
 Notes: _____



:: Rear Tires

Tire: Yokomo L-Rubber Medium
 Diameter: 41 mm
 Wheel Type: Yokomo (SP-1210-3)
 Additive: Paragon FXII
 Notes: _____



:: Body

Body Type and Make: Parma Zytec

Notes: _____

:: Track Info

smooth: bumpy:
 traction: high med. low
 Notes: _____

:: Motor/Battery

Motor: NOSRAM Pure Evo 5.5T
 Brush: _____ Spring: _____
 Timing: _____ Gear: 23 / 90
 Battery: _____
 Battery Position:
 Front Back

:: Transmitter

Turning Circle: _____
 Steering Expo: _____
 Brake E.P. : _____
 Throttle Expo: _____
 Notes: _____

:: Speed Control

S.C. : Nosram Pearl Evo
 S.C. Settings: 2-1-0-0

Translation from Japanese: Kimihiko Yano