

:: Driver: Andrew Doherty **:: Date:** 9/7/09
:: Track: _____
:: Event: 2009 IIC SuperStock 12th. Q19th, F17th.

Setup Sheet for Team Associated's 12R5

Reset Forms **Rev. 1**

:: Front Suspension

Kingpin Lube: SM Blue Tube Spooge
 Springs: AE .020"
 Upper Arm Mounts: 0° 5° 10°
 Camber: 1.5 Axle Spacers: .032"
 Bump Steer Spacers: Silver Stud
 Caster:
 thick thin thin thick thick and thin

 1.80° 3.25° 6.15°
 Ride Height: 3.5 mm

Notes: 1.5 mm shims between lower arm and bulkhead on each side. .048" spacers at top of king pin. .016" spacer on top of steering block.

Futaba 9650 mounted 2 mm forward of stk mounts. Kimbrough 201 ss with studs in lower holes.

:: Front Tires

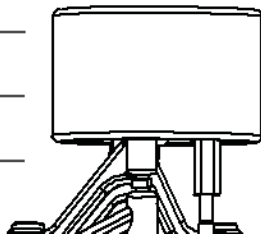
Tire: Jaco Black
 Diameter: 41.7 mm
 Wheel Type: _____
 Additive: JTG Inside 1/3
 Notes: Blue Losi CA on outside edge.



:: Rear Suspension

Side Spring: Gold
 T-Plate: _____
 Ride Height Adjuster: IRS
 Ride Height: 3.5 mm
 Side Shock
 Oil: AE 30
 Center Shock
 Oil: AE 25
 Spring: Blue
 Position: 

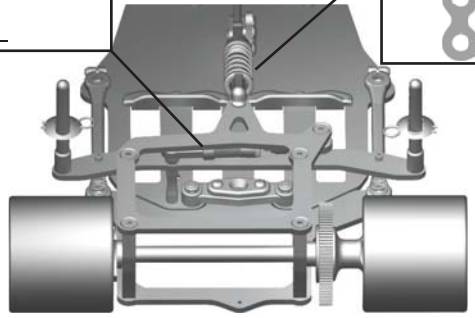

Notes: Max axle width. 10R5 rear pod. 2 mm spacer in center shock. Battery centered in slots. Yokomo center brace and spring perches. Springs all the way up.

:: Rear Tires

Tire: Jaco Orange
 Diameter: 44.1 mm
 Wheel Type: _____
 Additive: JTG Full Tire
 Notes: _____

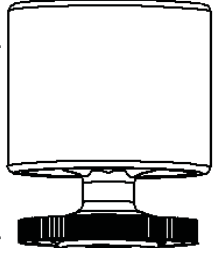

:: Body

Body Type and Make: Parma Speed8 HD LW
 Notes: Mounted a little on the high side.

:: Track Info

smooth: bumpy:
 traction: high med. low
 Notes: Small Booster wired to Rec.

:: Motor/Battery

Motor: SpeedPassion 13.5
 Brush: _____ Spring: _____
 Timing: N/A Gear: 76 / 42
 Battery: SMC 4900 40C
 Battery Position: Front Back

:: Speed Control

S.C. : Tekin RS V200
 S.C. Settings: Max timing. Max turbo. .3 delay

:: Transmitter

Turning Circle: 4.5'
 Steering Expo: 0
 Brake E.P. : 100
 Throttle Expo: 0
 Notes: ESCCalibrated at 130. Bumped to 140.
 TP-4 DB-10 NW-15 VC-off