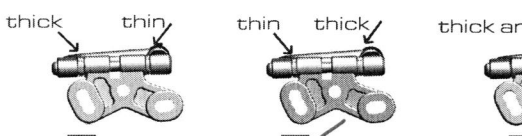

:: Driver: PAUL ASH **:: Date:** 18-5-08
:: Track: CHESTERFIELD
:: Event: CARS SUMMER SHOOT OUT ROUND 1

Setup Sheet for Team Associated's 12R5

Reset Fields **Rev. 1**

:: Front Suspension

Kingpin Lube: STEALTH GREASE
 Springs: 020"
 Upper Arm Mounts: 0° 5° 10°
 Camber: - 1.5 DEG
 Caster:

 1.80° 3.25° 6.15°
 Ride Height: 3-5mm
 Notes: FRONT TRACK WIDTH 2 SHIMS ON AXLE ONLY

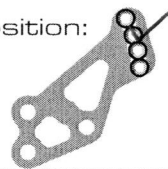
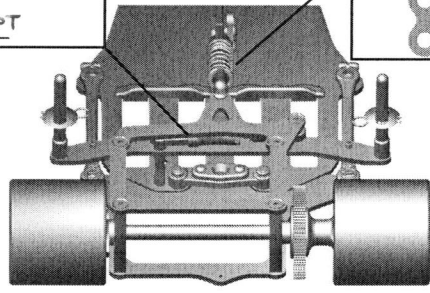
:: Rear Suspension

Side Spring: BLACK
 T-Plate: _____
 Ride Height Adjuster: _____
 Ride Height: 3-5mm
 Side Shock
 Oil: 10WT
 Center Shock
 Oil: 30WT
 Spring: GOLD
 Position: 

 Notes: 1 TURN OF PRE LOAD ON SIDE SPRINGS. CENTRE SHOCK ADJUSTED SO CHASSIS SITS LEVEL

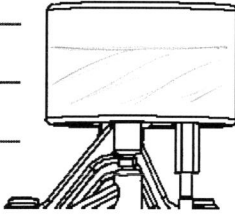
:: Front Tires

Tire: JACO PRISM MAGENTA
 Diameter: 43mm
 Wheel Type: JACO
 Additive: CS GPI-P
 Notes: ADDITIVE 60% ON INSIDE OF TYRE



:: Rear Tires

Tire: JACO PRISM YELLOW
 Diameter: 46mm
 Wheel Type: JACO
 Additive: CS GPI-P
 Notes: _____

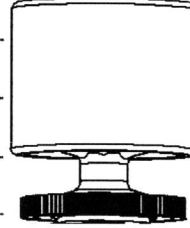

:: Body

Body Type and Make: PARMA ZYTEC
 Notes: _____

:: Motor/Battery

Motor: 5-5 BRUSHLESS
 Brush: _____ Spring: _____
 Timing: _____ Gear: 23 / 96
 Battery: SMC 4600
 Battery Position:
 Front Back

:: Transmitter

Turning Circle: 1-SMTR
 Steering Expo: - 5%
 Brake E.P.: _____
 Throttle Expo: LINEAR
 Notes: _____

:: Track Info

smooth: bumpy:
 traction: high med. low
 Notes: CAR VERY GOOD THROUGH CHICANE, HOOKED UP WELL IN TIGHT TURNS

:: Speed Control

S.C.: _____
 S.C. Settings: _____