

Camber
+ 0 -

Hex Spacing

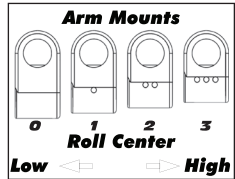
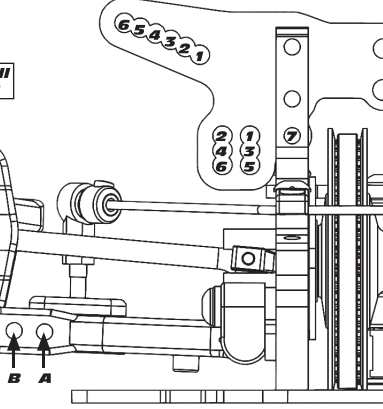

FRONT OF CAR

B A

FWD Mount

RWD Mount

Transmitter

Turning Circle:

Steering Expo:

Brake E.P.:

Throttle Expo:

Motor

Notes:

Gearing

/

Notes:

Front	Alignment	Rear
	Ride Height	
	Camber	
	Caster	N/A
N/A	Rear Hub Toe	
	Toe (Total)	
	Hex Spacing	
	Wheelbase	
	Steering Bellcrank	N/A
	Steering Link	N/A
	Bumpsteer	N/A

Notes:

Suspension Geometry

	Shock Position	
	Camber Link Position	
	Outer Ball & Shims	
	FWD Arm Mount	
	FWD Mount Shim	
	RWD Arm Mount	
	RWD Mount Shims	
	Drop	
	Anti-Roll Bar	

Notes:

Shocks

	Oil	
	Piston	
	Rebound	
	Spring	

Notes:

Differentials

	Type	
	Setting	
	Cam Holder	
	Belt Tension Number	

Notes:

Tires

	Type	
	Tire Diameter	
	Insert & Wheel	
	Additive & Amount	

Notes:

Chassis

	Chassis:	
	Top Plate:	
	Notes:	

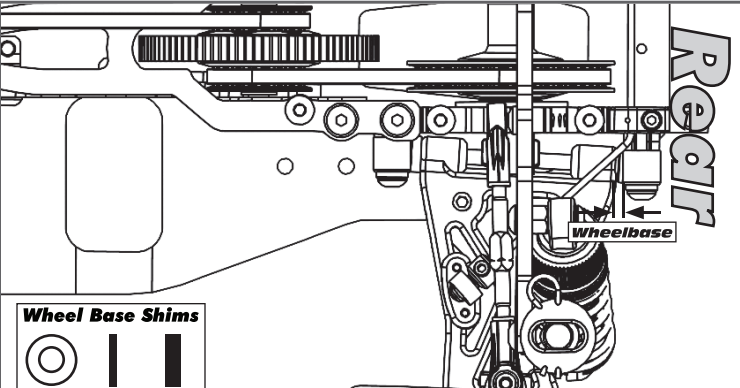

Wheel Base Shims



Arm Mount Shims



Toe 0

1° 1.5° 2°

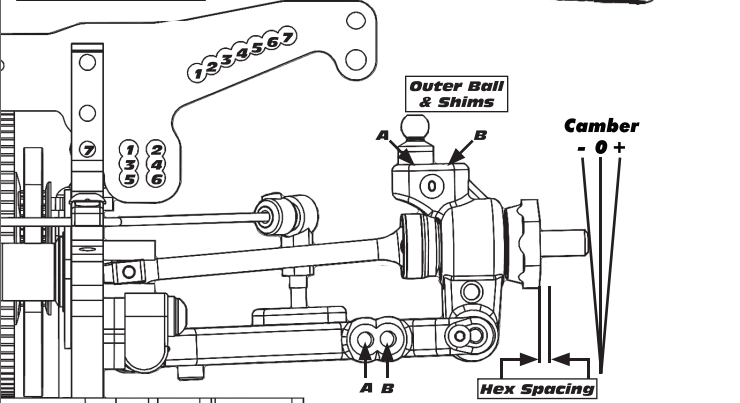

FRONT OF CAR

B A

FWD Mount

RWD Mount

Speed Control

Type:

Settings:

Body & Wing

Notes:

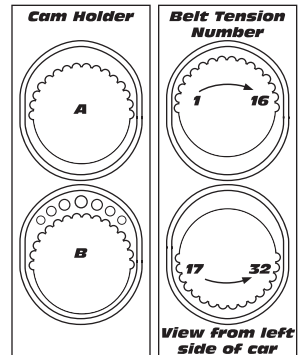

Battery Placement

Notes: