

TC5 Team

Factory Setup Data

Name: Juho Levanen
Event: US Indoor Championships (Cleveland)
Conditions: High Traction Ozite Carpet With Paragon

Date: 11/2007
Track: Holiday Inn Ballroom

For Team Driver's setups, please visit www.RC10.com, www.TeamAssociated.com or www.CompetitionX.com!

Rear

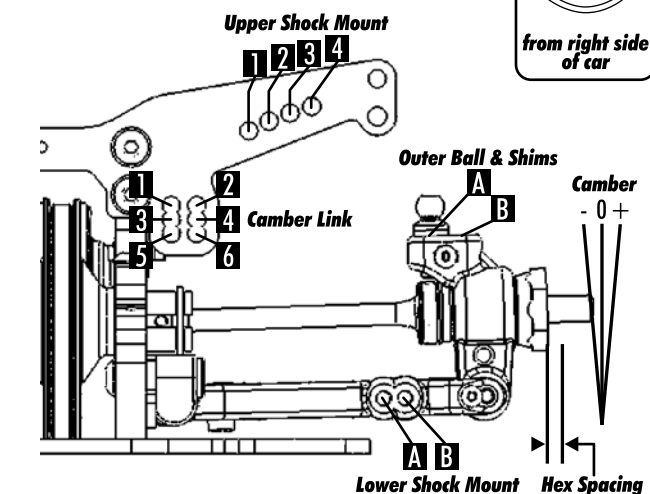
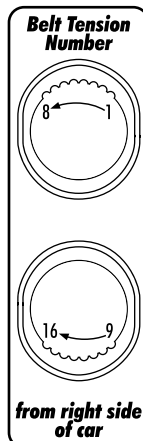
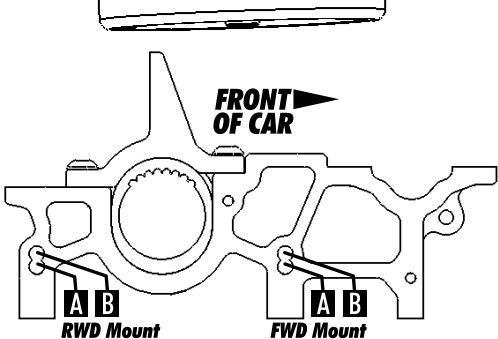
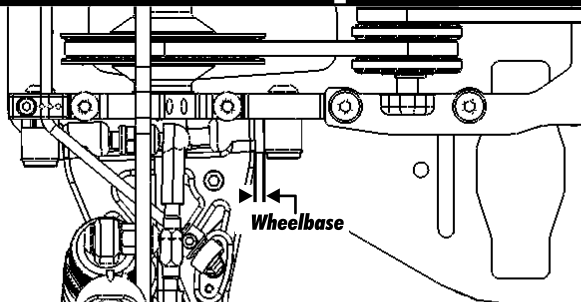

Body & Wing

Parma Mohawk Lightweight

Battery

Reedy VMXR4200 6 Cell

Rear	Alignment	Front
4.5mm	Ride Height	4.5mm
-3.5 Deg	Camber	-3 Deg
N/A	Caster	6 Deg
1 Deg	Rear Hub Toe	N/A
2 Deg	Toe	0 Deg
+0.5mm	Hex Spacing	+ 1.0mm
2mm	Wheelbase	2mm
N/A	Steering Link	1-A
N/A	Bumpsteer	Black- 3mm

Notes:

Differentials

Aluminum Diff	Type	Aluminum Diff
Loose	Setting	Loose
8	Belt Tension Number	9
A	Cam Holder	A

Notes:

Tires

Jaco Magenta	Tire	Jaco Magenta
56.5mm	Tire Diameter	56.5mm
Prism	Insert & Wheel	Prism
Full	Additive & Amount	Inside 1/2

Notes: Paragon For 15 Minutes

Shocks

30wt	Oil	50wt
#57	Piston	#57
20%	Rebound	20%
Blue	Spring	Purple

Notes:

Chassis

Chassis: Standard
 Top Plate: Standard
 Notes:

Suspension Geometry

2B	Shock Position	2B
5-A	Camber Link Position	4
Black - 2mm	Outer Ball & Shims	Black - 0mm
3A	FWD Arm Mount	2A
2 Deg	FWD Mount Shims	2 Deg
3A	RWD Arm Mount	2A
4 Deg	RWD Mount Shims	2 Deg
5	Droop	6
None	Anti-Roll Bar	None

Notes: Droop measured with AE gague under hinge pin

Front

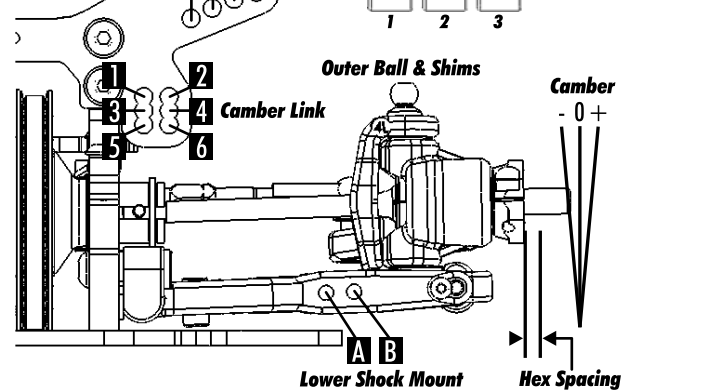
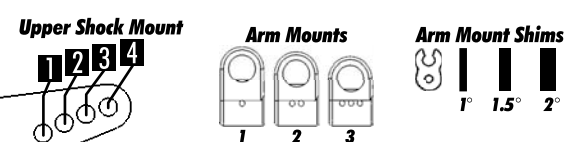
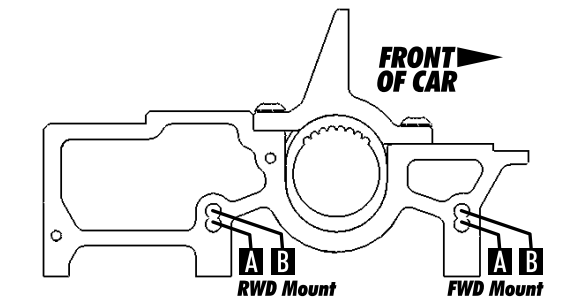
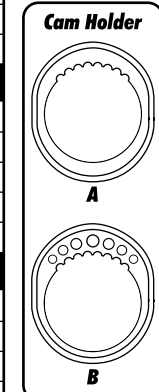
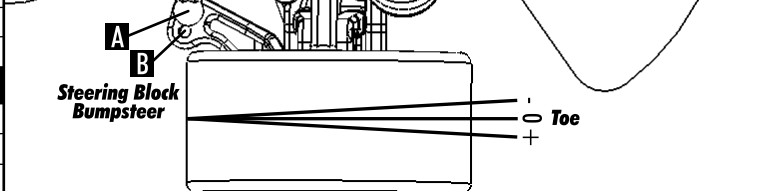
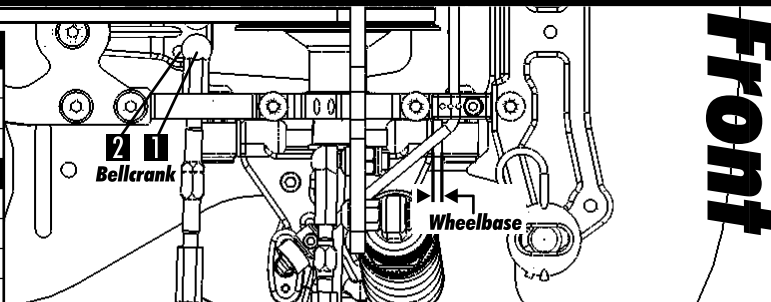

Motor

LRP X-11 4.0 Turn / 19 Turn

Gear

87/19 / 87/28

Brush

LRP Sphere Comp TC

Spring

Settings = 2/5/0/0

Timing

N/A