

Name: Craig Drescher / Brent Thielke
Event: International Indoor Championships
Conditions: Rubber Tires On Carpet

Date: Sept 2007
Track: South Point Hotel

For Team Driver's setups, please visit www.RC10.com, www.TeamAssociated.com or www.CompetitionX.com!

Rear

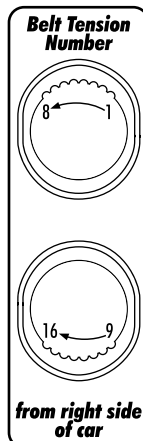
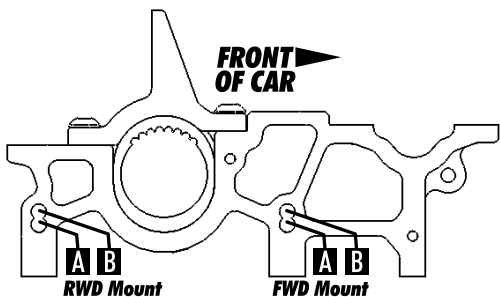
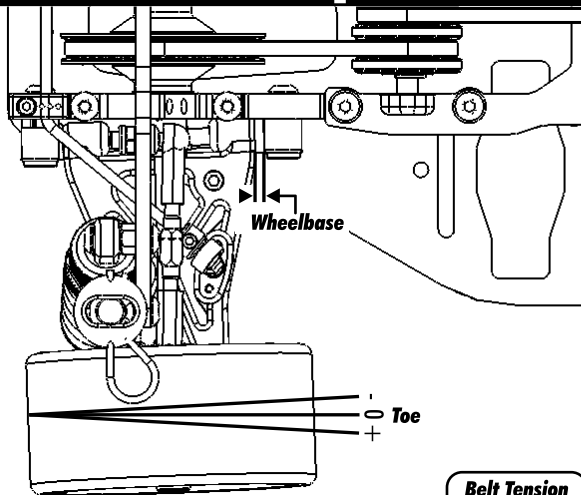

Upper Shock Mount

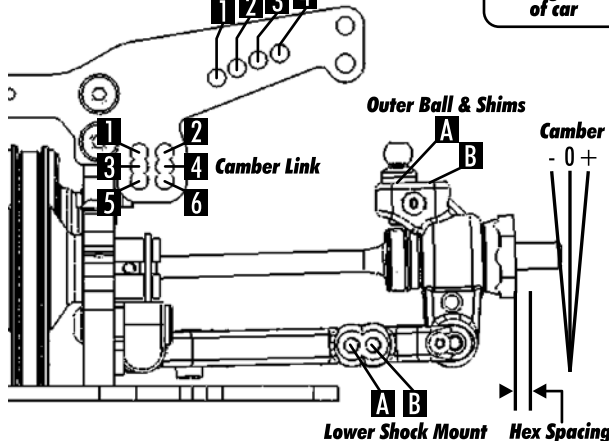

Body & Wing

Protoform Mazda 6 Standard Weight / Wing Back

Battery

Reedy IB4200 5 Cell

Rear	Alignment	Front
5.5 mm	Ride Height	5.0 mm
-2 Deg	Camber	-2 Deg
N/A	Caster	4 Deg
0 Deg	Rear Hub Toe	N/A
3.0 Deg	Toe	0 Deg
N/A	Hex Spacing	N/A
2 mm	Wheelbase	1 mm
N/A	Steering Link	1-A
N/A	Bumpsteer	3 mm

Notes:

Differentials

Aluminum Diff	Type	One-Way
Standard	Setting	N/A
7	Belt Tension Number	2
A	Cam Holder	A

Notes:

Tires

Jaco Green	Tire	Jaco Green
N/A	Tire Diameter	N/A
Spec	Insert & Wheel	Spec
Full	Additive & Amount	1/2 Inside

Notes: Jack The Gripper

Shocks

50 wt.	Oil	40 wt.
#2	Piston	#3
50%	Rebound Spring	50%
Silver	Spring	Blue

Notes: No Rebound Foam

Chassis

Chassis: ITF
 Top Plate: ITF
 Notes: 4 O-Rings On Rear Top Deck

Suspension Geometry

3-B	Shock Position	2B
3-A	Camber Link Position	3
Silver w/ 2mm	Outer Ball & Shims	Black w/ 0mm
2-A	FWD Arm Mount	1-A
1 Deg	FWD Mount Shims	0
2-A	RWD Arm Mount	1-A
4 Deg	RWD Mount Shims	0
6	Droop	7
Silver	Anti-Roll Bar	Silver

Notes: Use long screws on RWD Rear arm mounts.

Front

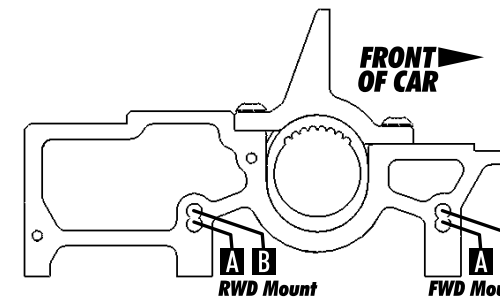
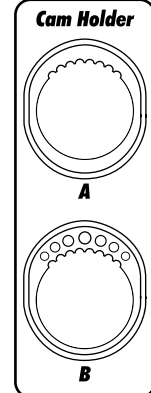
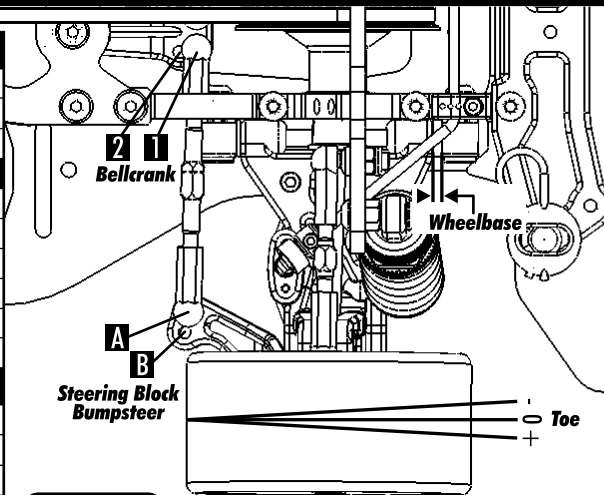

Upper Shock Mount



Arm Mounts



Arm Mount Shims

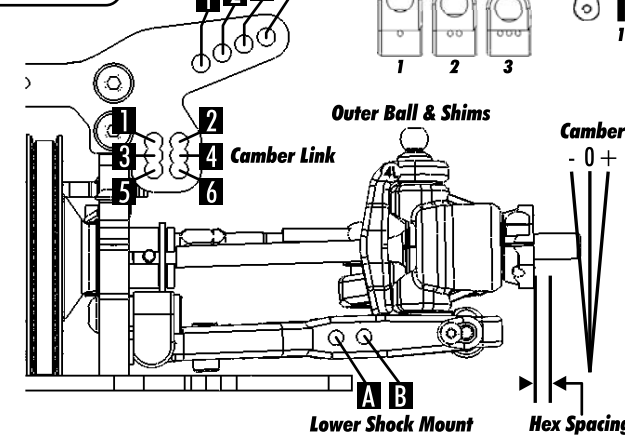

Motor

LRP 4.5 Turn Brushless

Gear

21 / 87

Brush

N/A

Spring

N/A

Timing

N/A