

Front	Alignment	Rear
5 mm	Ride Height	5.3 mm
-1.5 Deg	Camber	-2 Deg
4	Caster	N/A
N/A	Rear Hub Toe	0
- 1/2	Toe (Total)	3
0.75 mm	Hex Spacing	0.5 mm
1 mm	Wheelbase	2 mm
1-A	Steering Link	N/A
2 mm	Bumpsteer	N/A

Notes: All Hard Plastic Parts

Suspension Geometry		
2-B	Shock Position	2-B
3	Camber Link Position	3-A
Silver-0	Outer Ball & Shims	Black-2mm
3A	FWD Arm Mount	3A
0	FWD Mount Shims	0
3A	RWD Arm Mount	3A
0	RWD Mount Shims	2.5 mm
5	Droop	6
None	Anti-Roll Bar	Black

Notes: 2mm uptravel; All Hard Plastic Parts

Shocks		
55 wt	Oil	35 mm
3 x #56	Piston	3 x #56
None	Rebound	None
Blue	Spring	Silver

Notes: Air bleeder hole drilled in cap

Differentials		
Slipper Spool	Type	Aluminum Diff
N/A	Setting	Tight
Mid-High	Cam Holder	Mid-Low
A1	Belt Tension Number	A26

Notes:

Tires		
Jaco Blue	Tire	Jaco Blue
N/A	Tire Diameter	N/A
Spec	Insert & Wheel	Spec
Jack	Additive & Amount	Jack

Notes: Full sauce front & rear; No glued sidewalls; 20 min

Chassis
 Chassis: ITF Chassis
 Top Plate: ITF Top Plate
 Notes: Full Stiff

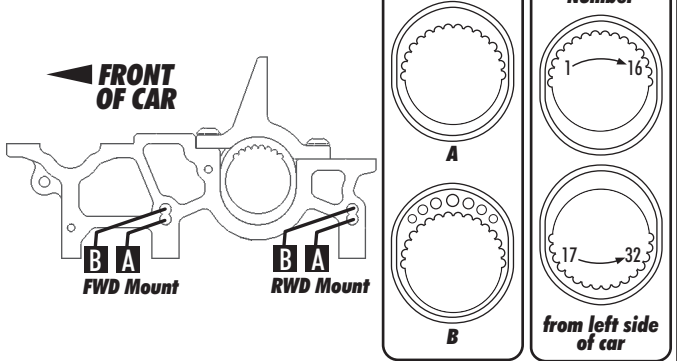
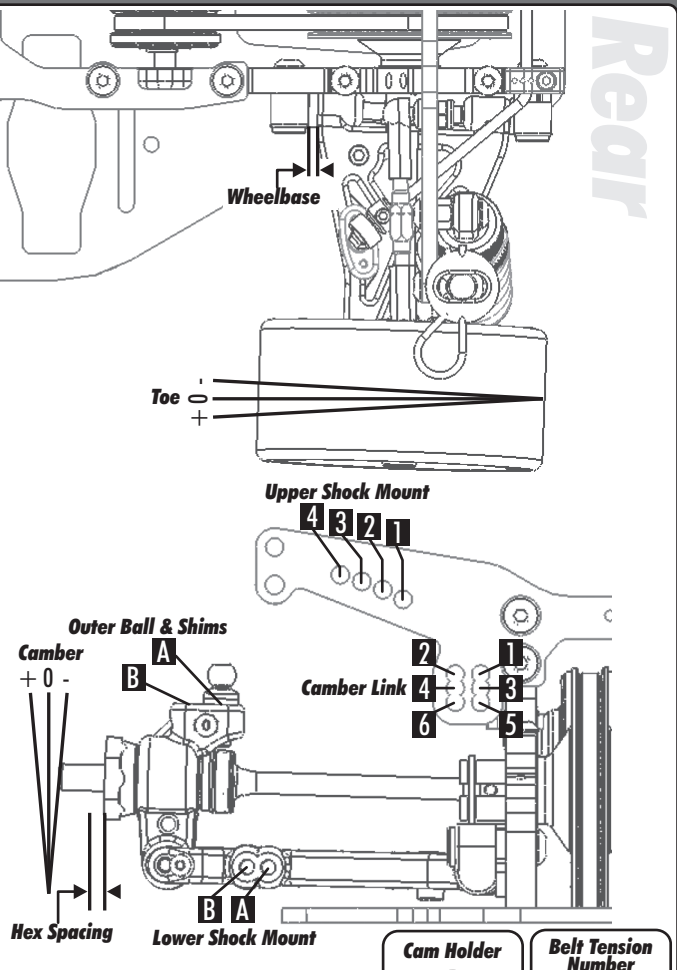

Transmitter	
Turning Circle:	80% Dual Rate
Steering Expo:	0%
Brake E.P. :	75%
Throttle Expo:	0%
Speed Control	
S.C. Type:	LRP SPX
S.C. Settings:	1/8/3/3

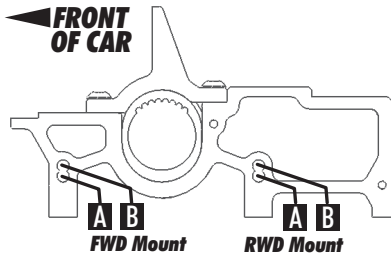

Motor	Gear	Notes
13.5 Turn	29 / 81	

Body & Wing
 PROTOForm Mazdaspeed 6

Battery
 Reedy 5000 35C #709