

Track Info:

Size: Small Medium
 Large X-Large

Surface: Carpet Asphalt
 Indoor Outdoor

Traction: Low Medium
 High Wet

Condition: Bumpy Smooth

Temperature: Ambient _____ Track _____

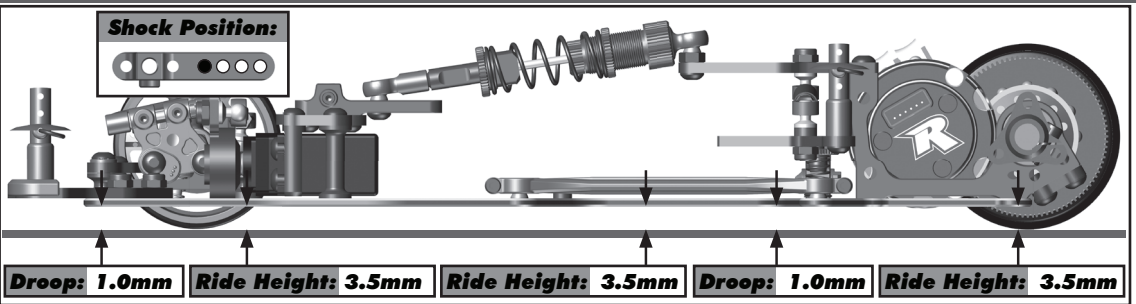

Vehicle Info:

Body: _____

Weight: _____

Notes: _____

Shock:

Piston: 1 x 1.0

Fluid: 30 Wt

Spring: 11.8 lb/in (Gray)

Rebound: 0

Pre Load: 3.2mm

Caster: 0mm 2°
 0.55mm 4°
 1.10mm 6°
 1.65mm 8°

Caster Shims: 2° (0.55mm)
 4° (1.10mm)

Dynamic Strut: 0°
 2.5°
 5°
 7.5°
 10°

Shim: 0

Track Width Inserts: Composite
 Aluminum
 0mm
 +0.5mm
 +1mm
 +1.5mm
 +2mm

Front Wheelbase: Std
 +2mm

Free Length: 80.2mm

Notes: _____

Diff Setting:

Loose Medium Tight

Electronics:

Radio: _____

Servo: _____

EPA: Throttle: _____ % Brake: _____ %

ESC: _____

ESC Settings: _____

Motor: _____

Timing: _____

Pinion: _____ **Spur:** _____

Rollout: _____

Battery: _____

Notes: _____

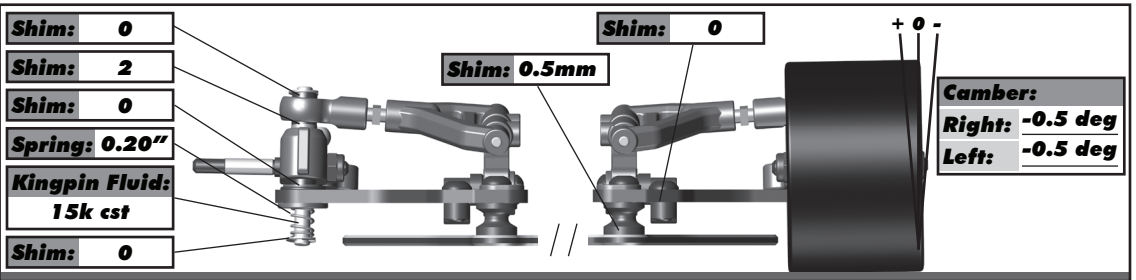

Side Spring: Pre Load: 0.5mm
 Spring: White

Damper Tube: Fluid: 15k cst

Axle Height: 1.0 0.75 0.5 0.25 0 0.25 0.5 0.75 1.0 STD + 1mm

Shim: 0

Shim: 0

Shim: 0

Shim: 0

Tires:

Front Tires: _____

Front Tire Dia: _____

Rear Tire: _____

Rear Tire Dia: _____

Notes: _____

Front Tire Additive:	Left	Right
	<input type="checkbox"/>	<input type="checkbox"/>
Additive Time:		
Rear Tire Additive:	<input type="checkbox"/>	<input type="checkbox"/>
	<input type="checkbox"/>	<input type="checkbox"/>
Additive Time:		

