

## Track Info:

**Size:** Small  Medium   
 Large  X-Large

**Surface:** Carpet  Asphalt   
 Indoor  Outdoor

**Traction:** Low  Medium   
 High  Wet

**Condition:** Bumpy  Smooth

**Temperature:** Ambient  Track

RESET

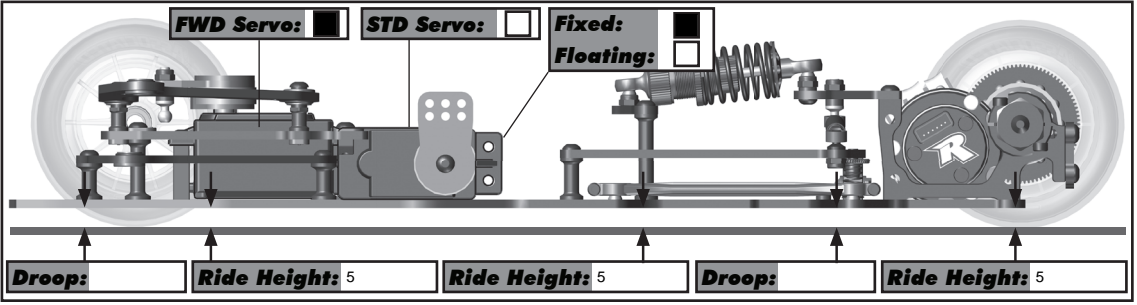

## Vehicle Info:

**Body:** Jconcepts javelin

**Weight:** 1069

**Notes:**

**Shock:**

**Piston:** Kit

**Fluid:** 40 wt

**Spring:** Green

**Rebound:** 1mm

**Pre Load:** 8mm

**Free Length:** 65mm

**Notes:**

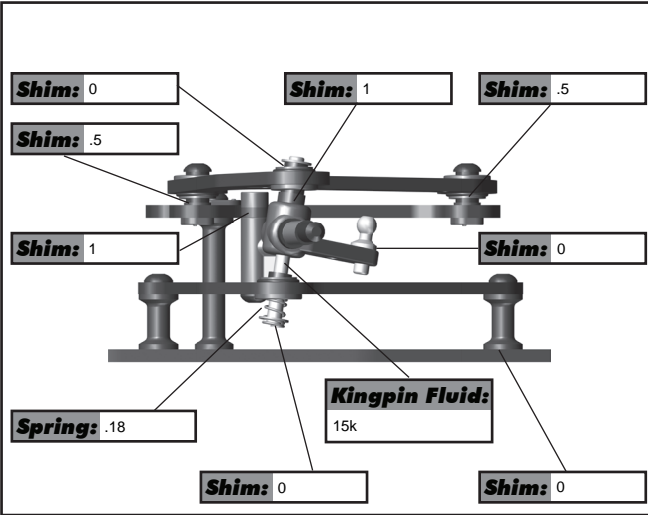

**Camber:** 1.0°  1.5°  2.0°  2.5°   
**Plastic:**  **Aluminum:**

**Caster:** 3°  6°  9°  12°   
**Plastic:**  **Aluminum:**

## Diff Setting:

Loose  Medium  Tight

## Electronics:

**Radio:**

**Servo:**

**EPA:** Throttle: % Brake: %

**ESC:** 510r

**ESC Settings:**

**Motor:** Reedy Mach 3 25.5

**Timing:** 35°

**Pinion:** 35 **Spur:** 96

**Battery:** Reedy zapper 27307

**Notes:**

## Shock:

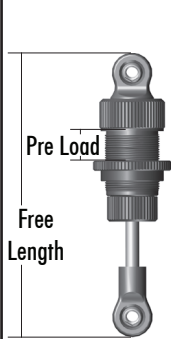

## Side Spring:

**Pre Load:** 0mm

**Spring:** 4642

## Damper Tube:

**Fluid:** 15k

## Rear Wing Height:

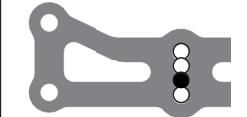

**Axle Height:** 1.0  0.75  0.5  0.25  0  0.25  0.5  0.75  1.0  STD + 1mm

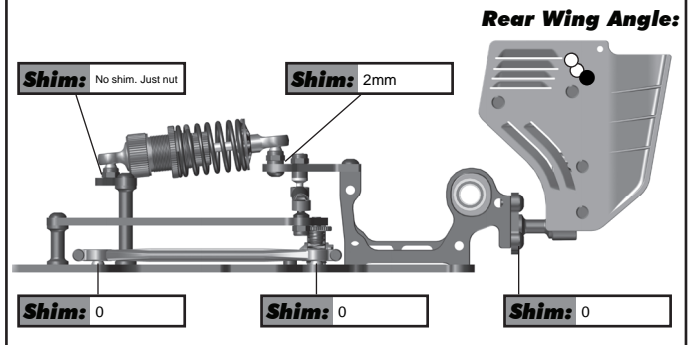

## Tires:

**Front Tires:** Pit 571

**Front Insert:** Stock

**Rear Tire:** Pit 575

**Rear Insert:** Stock

**Wheel (F/R):** Exotek +3mm

**Notes:**

**Front Tire Additive:** Sxt 3.0

**Additive Time:** 8 min

**Rear Tire Additive:** Sxt 3.0

**Additive Time:** 8 min

**Left** **Right**

**Toe:** 0

**Front Wing:** Ae

