

RACE

TRACK

NAME

CITY / COUNTRY

DATE

TEMPERATURE	AIR	TRACK	
QUALIFYING POSITION	BEST LAP TIME SEC	FINAL POSITION	RACE LENGTH MIN
TRACK LAYOUT <input type="checkbox"/> TECHNICAL <input type="checkbox"/> MIXED <input type="checkbox"/> FAST			
TRACTION <input type="checkbox"/> LOW <input type="checkbox"/> MEDIUM <input type="checkbox"/> HIGH			

GEAR RATIO CHART

Spur	Spur 1st			Spur 2nd		
Pinion	60	61	62	56	57	58
1st 19T	<input type="checkbox"/>	<input type="checkbox"/>	<input type="checkbox"/>	5.37	5.46	5.56
2nd 24T	7.26	7.38	7.51	<input type="checkbox"/>	<input type="checkbox"/>	<input type="checkbox"/>

Front		SHOCK		Rear	
OIL	<input type="checkbox"/> 1 HOLE	SHOCK PISTON	<input type="checkbox"/> 1 HOLE	OIL	<input type="checkbox"/> 1 HOLE
CST	<input type="checkbox"/> 2 HOLE	HOLE SIZE	<input type="checkbox"/> 2 HOLE	CST	<input type="checkbox"/> 2 HOLE
SPRING	<input type="checkbox"/>	<input type="checkbox"/>	<input type="checkbox"/>	SPRING	<input type="checkbox"/>

Front		TIRE		Rear	
Front Left	<input type="checkbox"/>	Shore	Rear Left	<input type="checkbox"/>	<input type="checkbox"/>
Front Right	<input type="checkbox"/>		Rear Right	<input type="checkbox"/>	
Front Left	<input type="checkbox"/>	Ø	Rear Left	<input type="checkbox"/>	<input type="checkbox"/>
Front Right	<input type="checkbox"/>		Rear Right	<input type="checkbox"/>	
<input type="checkbox"/>		Additive	<input type="checkbox"/>		<input type="checkbox"/>

Bumper

Standard Cut

BODY MOUNT DISTANCE mm

BODY WING mm

ENGINE

Engine	<input type="text"/>	Pipe	<input type="text"/>
Plug	<input type="text"/>	Carb Diameter	<input type="text"/> mm
Fuel	<input type="text"/>	Head Shims	<input type="text"/> mm

CLUTCH

Clutch Bell	<input type="text"/>	Clutch Shoes	<input type="text"/>
Spring Load	<input type="text"/> mm	Bell Clearance	<input type="text"/> mm

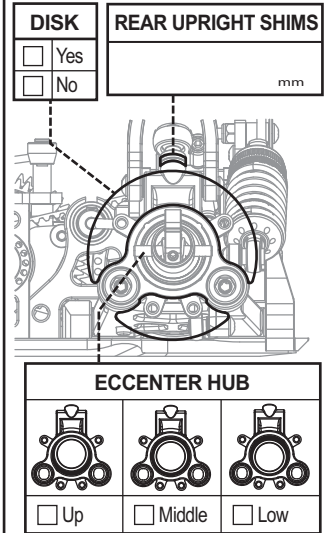
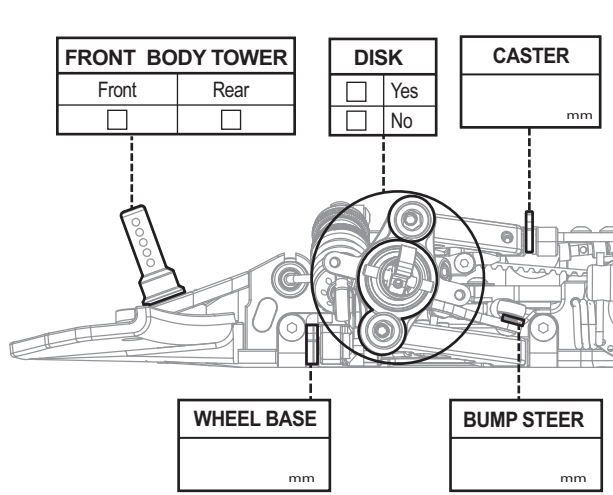

FRONT

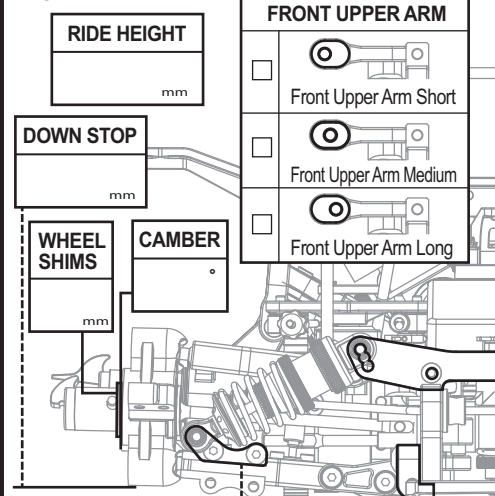

REAR

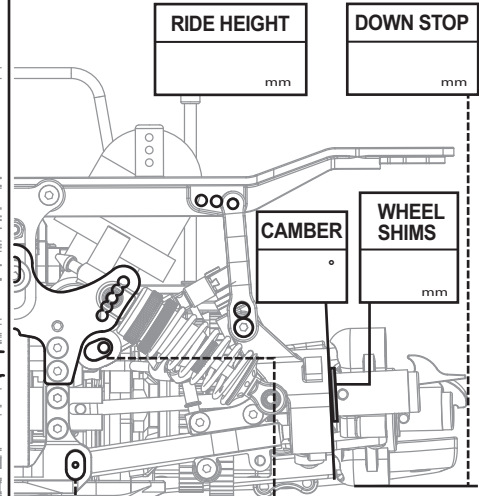

LONG	SHORT
<input type="checkbox"/> R802042	<input type="checkbox"/> R802041

+0mm	+2mm
<input type="checkbox"/> R801021	<input type="checkbox"/> R801022

REAR ROLL CENTER	<input type="checkbox"/>	<input type="checkbox"/>	<input type="checkbox"/>
-------------------------	--------------------------	--------------------------	--------------------------

REAR UPPER LINK	<input type="checkbox"/>	<input type="checkbox"/>	<input type="checkbox"/>
------------------------	--------------------------	--------------------------	--------------------------

