











NOTE :



 =Apply Thread lock adhesive

 =Apply CA Glue

 =Apply Grease





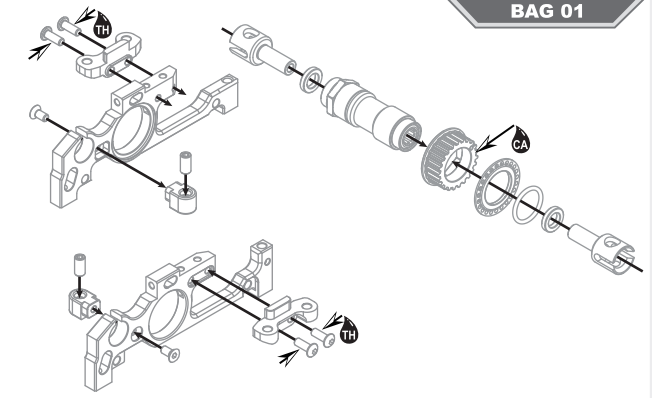

BAG 01

-  **R803059**
Front One Way Cup (2)
-  **R802019**
Front One Way
-  **R801111**
Pulley Set-Front
-  **R802020**
Front Upper Arm
Bracket Base
-  **R801104**
One Way Plastic
Shims (2)
-  **R804020**
O'Ring 10x1.5 (6)
-  **R802004**
Front Alu-Bulkhead-L
-  **R802005**
Front Alu-Bulkhead-R
-  **R801020**
Downstop Nut Holder (2)

-  **R105105**
3x8 Round Screw
-  **R105203**
3x6mm Flat Screw
-  **R805052**
4x8mm Set

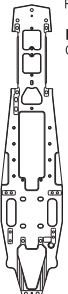





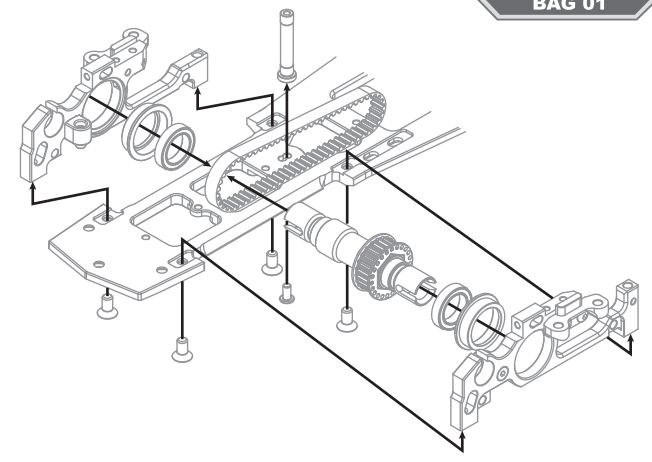

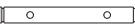

BAG 01

-  **R801042**
Bearing Bushing
-Front One Way (2)
-  **R803040**
Servo Saver Base Post
-  **R804030**
Front Belt 201
-  **R802003**
Chassis
-  **R806020**
12x18x4mm
Ball Bearing (4)
-  **R105104**
3x6 Round Screw
-  **R805201**
4x8mm Flat Screw



BAG 01

-  **R801111**
Pulley Set-Front
-  **R801041**
Bearing Bushing
-Middle Shaft (2)
-  **R802007**
Middle Shaft Block
-  **R803011**
Middle Shaft
-  **R801112**
Pulley Set-Middle
-  **R805101**
4x6 Round Screw
-  **R805045**
E-Clip 5mm (6)
-  **R806110**
Ø3x10.8 Pin (6)
-  **R806006**
6x13x5mm
Ball Bearing (2)

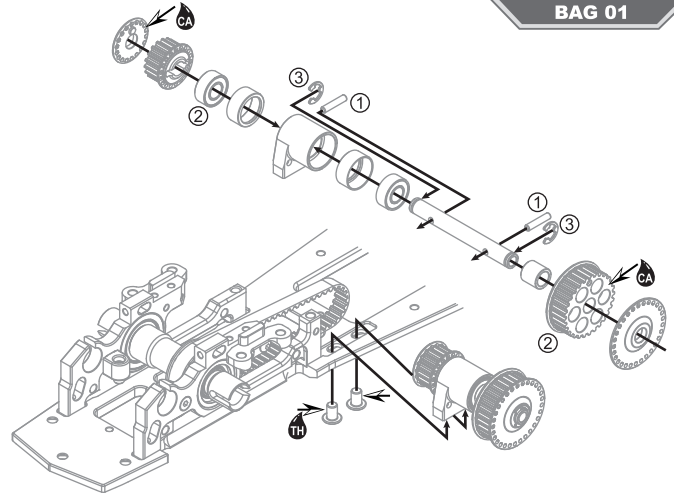

R807010
Servo Saver Spring

R802110
Servo Saver Tower

R802008
Servo Saver Alu

R801108
Ackerman Adjustment Shims (2) 0+1.5

R808010
Ackerman Plate 8.5mm Carbon

R105104
3x6 Round Screw

R106010
5x8x2.5mm Ball Bearing (2)

BAG 01

When track "High Traction" or want to reduce steering

Default

When track "Low Traction" or want to increase steering

R801090
Ball End 5.8mm Short (2)

R803015
Anti Roll Bar Ball Screw (2)

R803014
Anti Roll Bar Ball Head (2)

R802042
Front Shock Mount L (2)

R801015
Front Low Arm Set

R105104
3x6 Round Screw

R105105
3x8 Round Screw

R105101
2x5mm Cap Screw

BAG 02

R805104
4x12 Round Screw

R805102
4x8 Round Screw

R801021
Front Low Arm Holder (4)

R801022 (Optional)
Front Low Arm Holder +2mm (4)

R802006
Front Upper Arm Bracket

R803031
Front Low Arm Pin 3x77.8

R801094
Spacer 1mm/2mm/3mm

BAG 02

R801022 (Optional)
Front Low Arm Short

R802041

R801021
Front Low Arm Long

R802042
Front Shock Mount L

Can increase steering best for low traction track.

R801072
Front Upper Arm (2)

R803033
Front Upper Arm Pin 3x49 (2)

R801023
Suspension Bracket Insert-Open (8)

R801094
Spacer 3mm+2mm+1mm

R105401
3x3mm Set

BAG 02

BAG 02

Front Upper Arm Short

Front Upper Arm Medium

Default

Front Upper Arm Long

R801055
Steering Block

R803018
7.9mm Ball End Long (4)

R802045
Front Steering Plate (2)

R803062
Front CVD Shaft (2)

R803063
Front Wheel Axle (2)

R802032
Front Tire Hook (2)

R807004
Tire Hook Spring (4)

R803064
CVD Insert (2)

R804003
7.9mm Ball End Nut (4)

R105104
3x6 Round Screw

R105401
3x3mm Set

R806100
02.5x11.8 Pin (6)

R806101
03x19.8 Pin (6)

R806020
12x18x4mm Ball Bearing (4)

R803051
12.1x15x0.5mm

BAG 02

R803016
Ball Head 4.9mm (4)



R101070
Ball Joint 4.9mm Open (4)

R803035
3mmX62mm Rod (2)

BAG 02

BAG 02

BAG 02

-  **R105202**
3x5mm Flat Screw
-  **R105104**
3x6 Round Screw

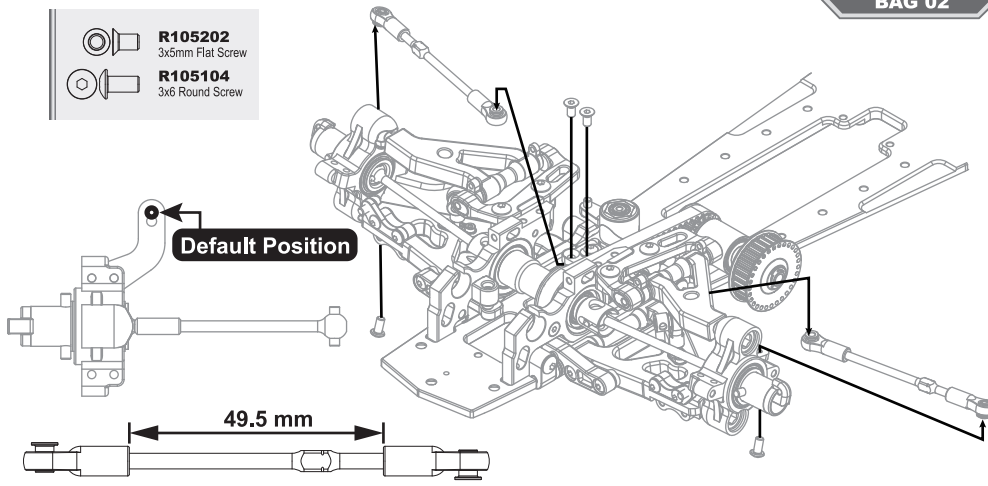



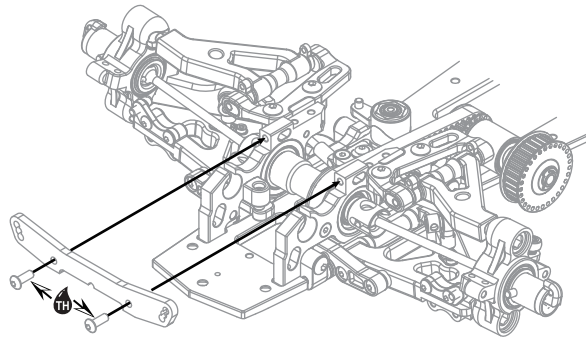

BAG 02

-  **R808002**
Front Shock Tower
-  **R105105**
3x8 Round Screw



BAG 02

-  **R803013**
Anti Roll Bar Stopper (2)
-  **R801046**
Anti-Roll Bar Bushing -Front (2)
-  **R807017**
Front Anti-Roll Bar 2,6mm
-  **R106010**
5x8x2,5mm
Ball Bearing (4)
-  **R105401**
3x3mm Set

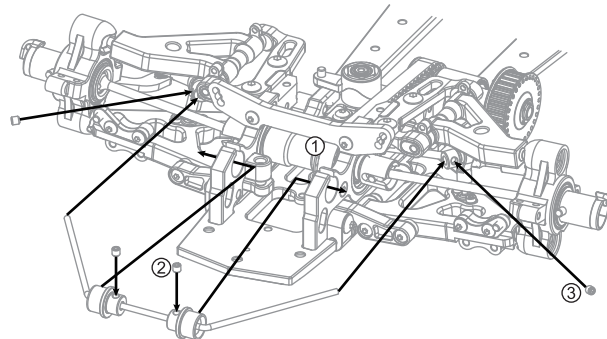

R8.0 2016 New Parts

-  **R802025**
Rear Low Bulkhead-High

-  **R801113**
Pulley Set-Rear





-  **R803010**
Rear Solid Axle

-  **R805040**
12mm C Clip (6)

-  **R802060**
Rear Low Arm Brackets RF

-  **R801024**
Suspension Bracket
Insert-Closed (8)

-  **R804031**
Rear Belt 201-8
-  **R801040**
Excenter Bushing Solid Axle (2)

-  **R805201**
4x8mm Flat Screw
-  **R105204**
3x8mm Flat Screw
-  **R806020**
12x18x4mm
Ball Bearing (4)
-  **R806101**
Ø3x19,8 Pin (6)

BAG 03

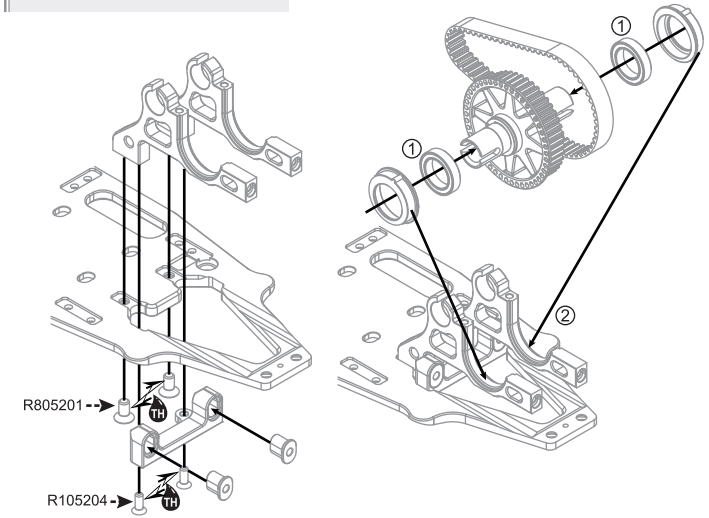
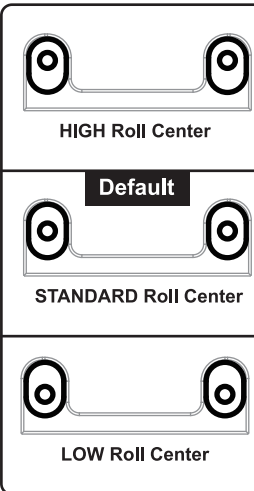
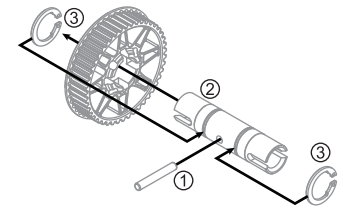

BAG 03

-  **R808006**
Rear Upper Link Plate

-  **R808003**
Rear Shock Tower

-  **R802022**
Rear Bulkhead Upper





-  **R105204**
3x8mm Flat Screw

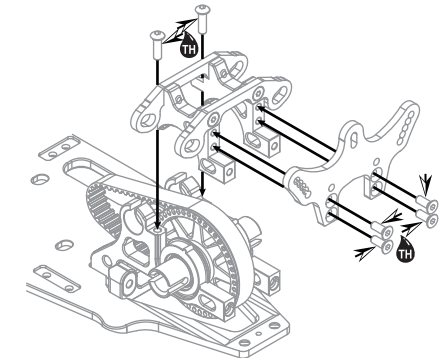
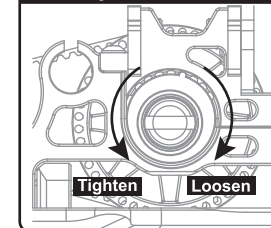



-  **R105106**
3x10 Round Screw

To Adjust belt tension



BAG 03

-  R801010 Rear Low Arm
-  R802061 Rear Low Arm Brackets RR
-  R801024 Suspension Bracket Insert-Closed (8)
-  R802048 Rear Shock Mount S (2)
-  R803032 Rear Low Arm Pin (2)

-  R105104 3x6 Round Screw
-  R105105 3x8 Round Screw
-  R805201 4x8mm Flat Screw
-  R805053 4x10mm Set

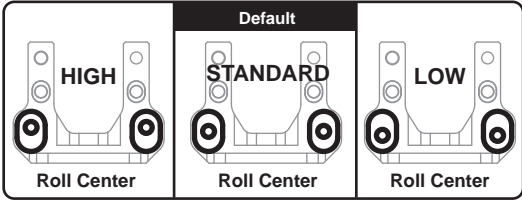
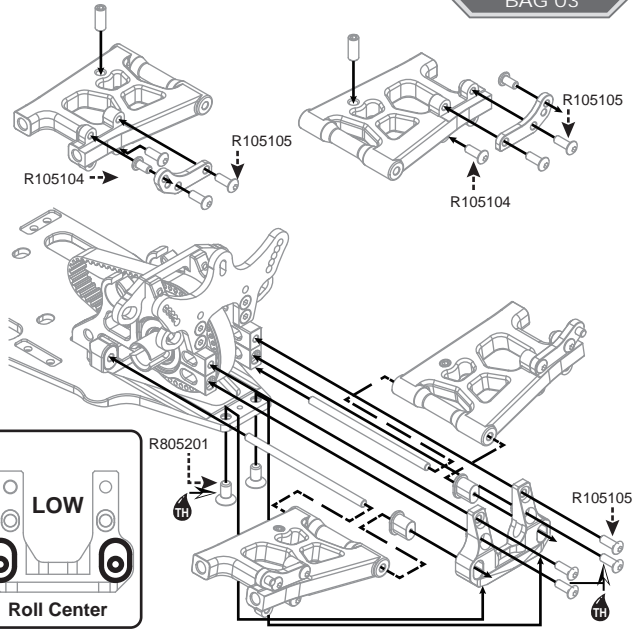





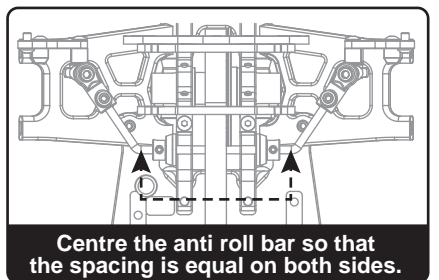
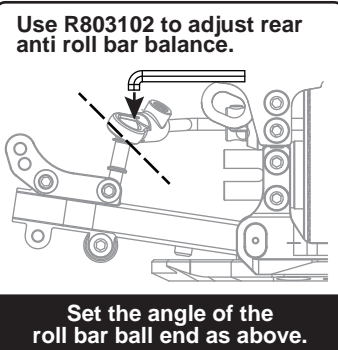
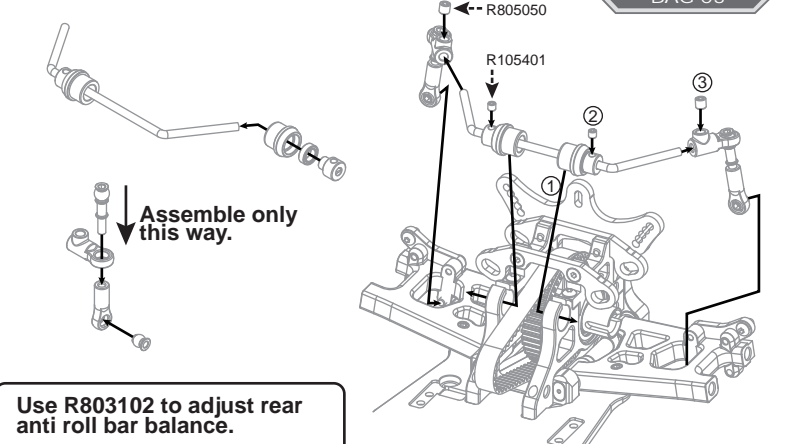

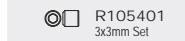
BAG 03

-  R807021 Rear Anti-Roll Bar 2.6mm
-  R801047 Anti-Roll Bar Bushing -Rear (2)
-  R803013 Anti-Roll Bar Stopper (2)
-  R803019 Anti-Roll Bar Adj Screw (2)
-  R801092 Rear Anti-Roll Bar Ball End (2)
-  R803016 Ball Head 4.9mm (4)
-  R101070 Ball Joint 4.9mm Open (4)
-  R803102 Anti-Roll Bar Tool



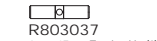

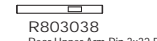



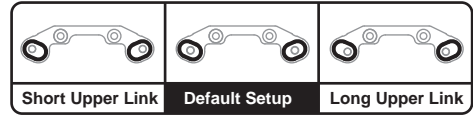
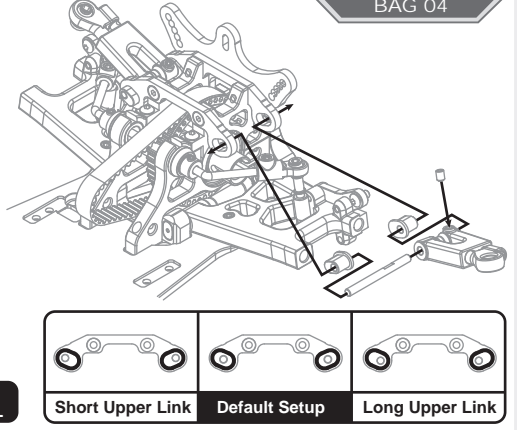
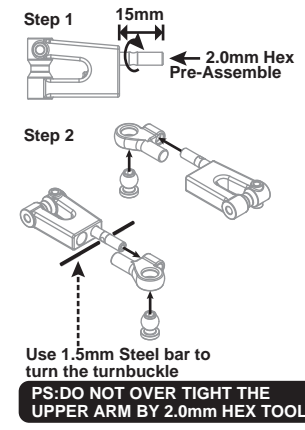



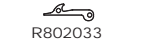

-  R106010 5x8x2.5mm Ball Bearing (2)
-  R105401 3x3mm Set
-  R805050 4x4mm Set

BAG 04

-  R801093 Rear Upper Arm Set
-  R803024 Ball Head 6.8mm (2)
-  R803037 4mmx17mm Turnbuckle (2)
-  R801023 Suspension Bracket Insert-Open (8)
-  R803038 Rear Upper Arm Pin 3x32.5 (2)
-  R105401 3x3mm Set

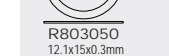

BAG 04

-  R802033 Rear Tire Hook (2)
-  R807004 Tire Hook Spring (4)
-  R804003 7.9mm Ball End Nut (4)
-  R803017 7.9mm Ball End Short (4)
-  R801050 Rear Upright
-  R803060 Rear Wheel Axle (2)
-  R801043 Exciter Rear Upright Bushing +1mm (x4) +0mm (x4)
-  R803050 12.1x15x0.3mm
-  R806020 12x18x4mm Ball Bearing (4)
-  R803051 12.1x15x0.5mm
-  R105401 3x3mm Set
-  R806101 03x19.8 Pin (6)
-  R805307 3x16 Set Screw (6)

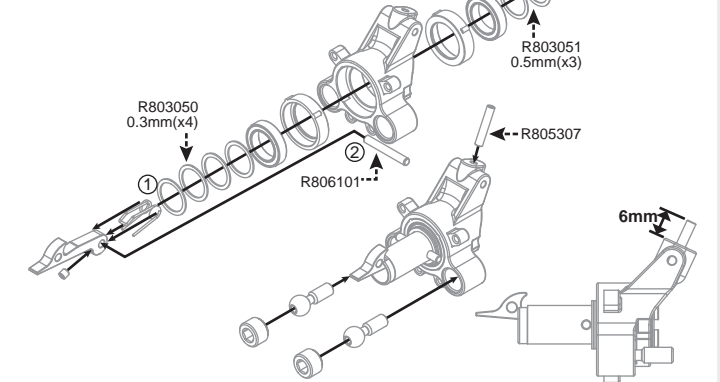
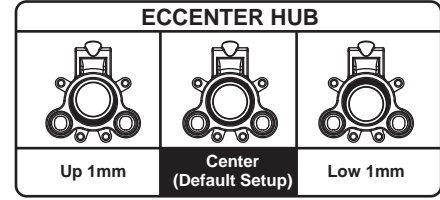

BAG 04

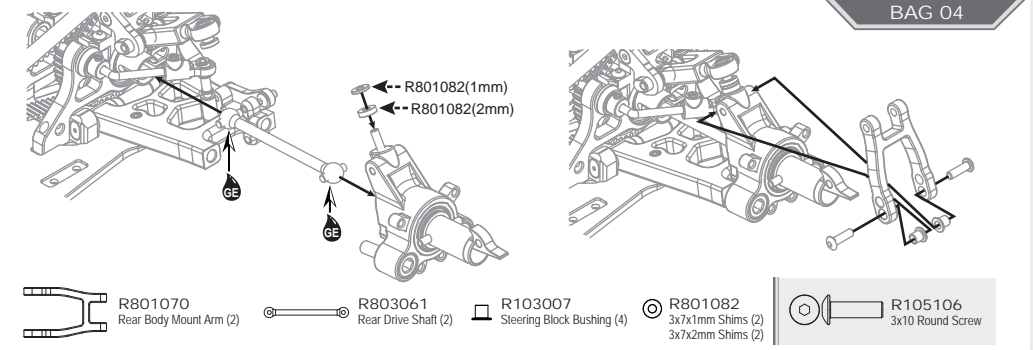

-  R801070 Rear Body Mount Arm (2)
-  R803061 Rear Drive Shaft (2)
-  R103007 Steering Block Bushing (4)
-  R801082 3x7x1mm Shims (2) 3x7x2mm Shims (2)
-  R105106 3x10 Round Screw

BAG 04

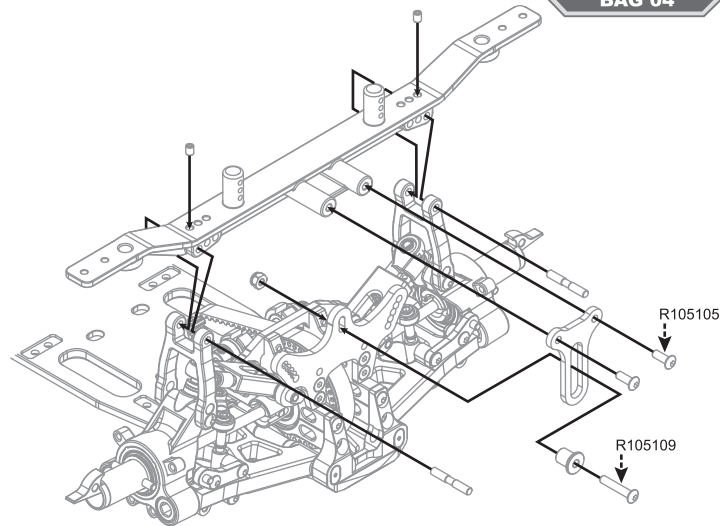
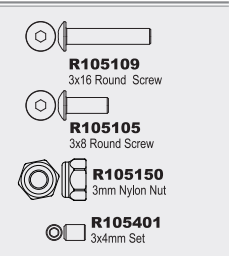
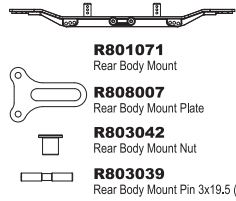

BAG 05

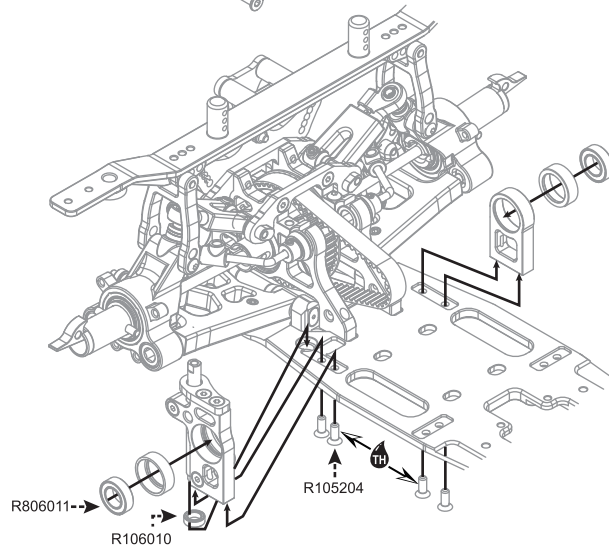
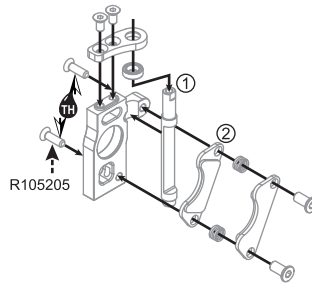
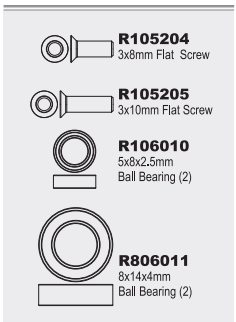
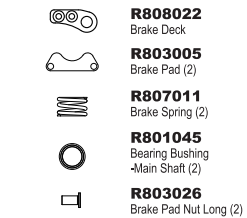
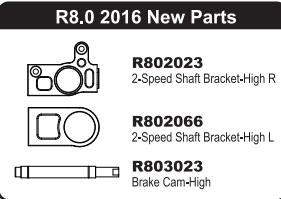

BAG 05

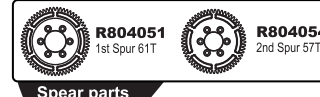

Spear parts

Option parts

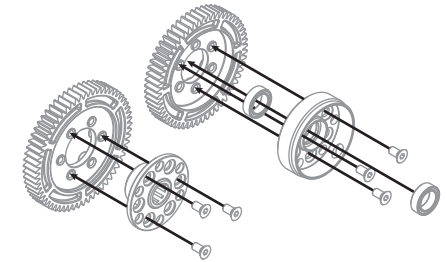
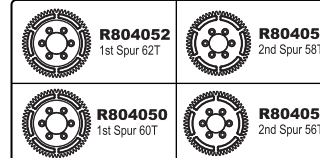
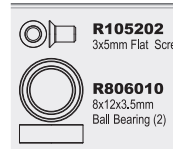

BAG 05

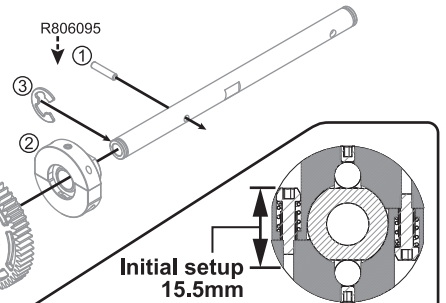
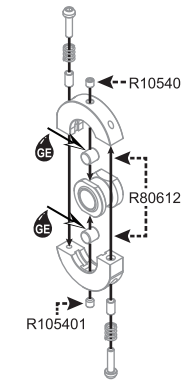
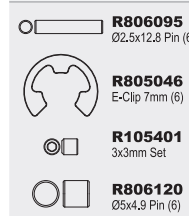
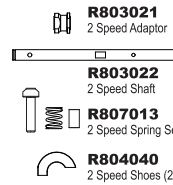

Note:
By tightening the screws, the 2 speed clutch will engage later, while loosening the screws will make the 2 speed clutch engage earlier.

BAG 05

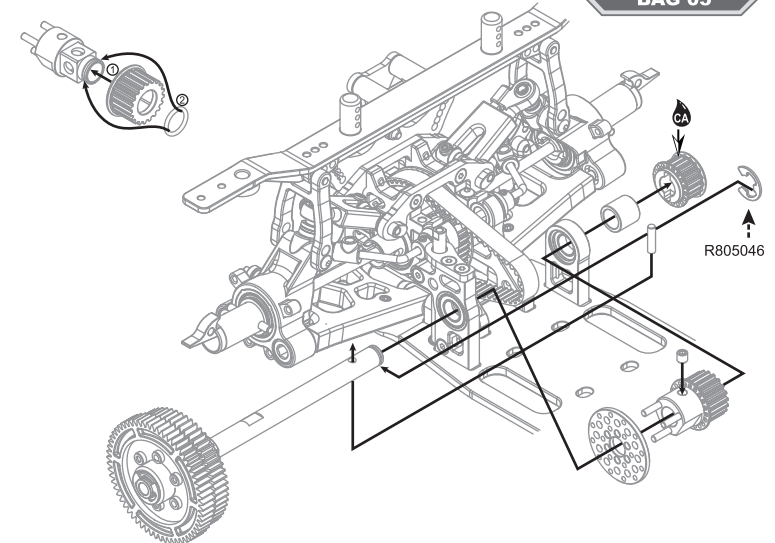
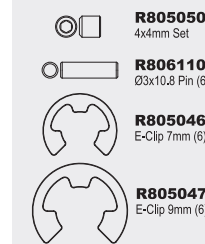
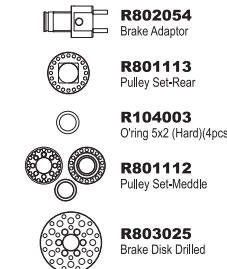

BAG 05

R802011
Center Bulkhead

R807031
Rollover Bar

R802050
Belt Tensioner Shaft (2)

R808005
Belt Tensioner Plate

R804032
Middle Belt 435

R105104

R806005

R105109

R806005
5x10x4mm
Ball Bearing (2)

R805050
4x4mm Set

R105204
3x8mm Flat Screw

R105104
3x6 Round Screw

R105109
3x16 Round Screw

BAG 05

R801060
R 8.0 Bumper/Body Tower Set

R805302
4mm

R805102
4x8 Round Screw

R805203
4x12mm Flat Screw

BAG 06

R104021
Shock Piston Big Bore
Long 1,1mm x2

R104022
Shock Piston Big Bore
Long 1,1mm x1

R103013
Shock Shaft (2)

R104013
O'ring 13x1

R101040
Shock Ball Joint Set

R102009
Shock Low Cap Alu (2)

R102010
Shock ADJ Nut Alu (2)

R104002
O'ring 3x2

R104015
Shock Shaft Shim

R105501
E-Clip 2mm (10)

Front

Rear

R8.0 2016 New Parts

R802027
Shock Cap-V2016 (2)

R802026
Shock Body-V2016(2)

BAG 06

R101040
Shock Ball Joint Set

R104001
Shock Chamber (4)

#500

BAG 06

R101040
Shock Ball Joint Set

R103027
5,8mm Ball End Short (4)

R807052
Shock Spring Front (Red)

R807061
Shock Spring Rear (Blue)

BAG 06

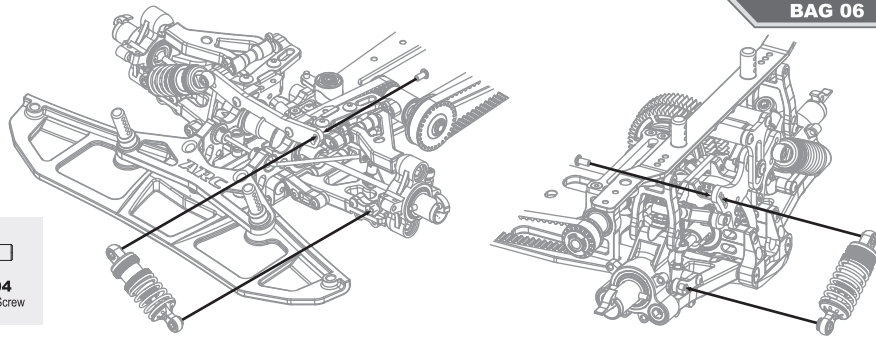

R105104
3x6 Round Screw

BAG 07

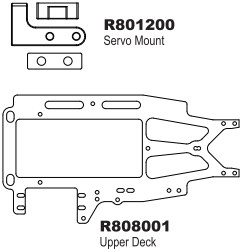

R801200
Servo Mount

R808001
Upper Deck

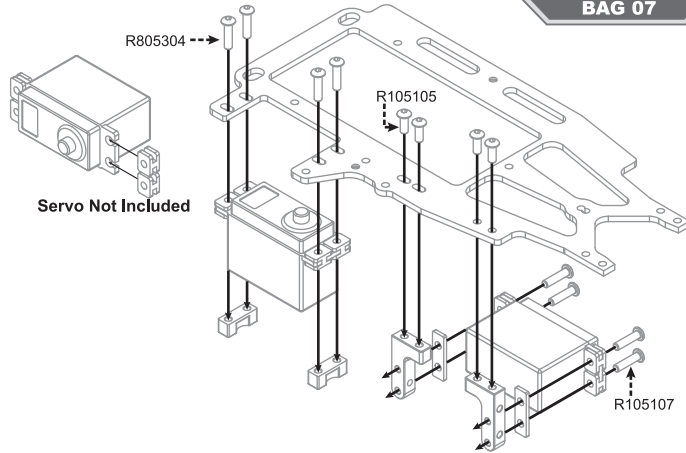

Servo Not Included

BAG 07

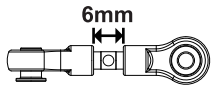

6mm

Suggested Servo wire layout

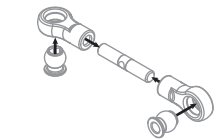

R801091
Ball End 4.9mm Short (2)

R803016
Ball Head 4.9mm (4)

R803034
3mm X 15mm Turnbuckle (2)

R101060
Servo Horn Dual Steering Arm

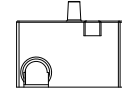

R801080
Radio Box

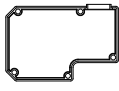

R801081
Radio Box

R804021
Rubber Grommet

R104150
Antenna

R805305
2x8 Flat Screw

R105104
3x6 Round Screw



R804021

Receiver Not Included

BAG 07

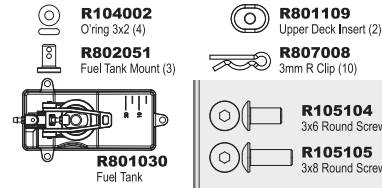

R104002
O-ring 3x2 (4)

R802051
Fuel Tank Mount (3)

R801109
Upper Deck Insert (2)

R807008
3mm R Clip (10)

R105104
3x6 Round Screw

R105105
3x8 Round Screw

R801030
Fuel Tank

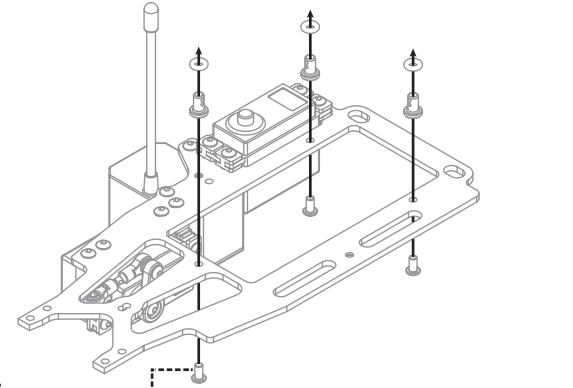
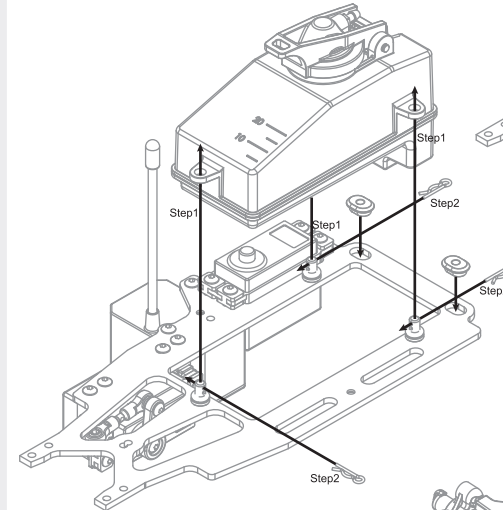

R105105
R105104

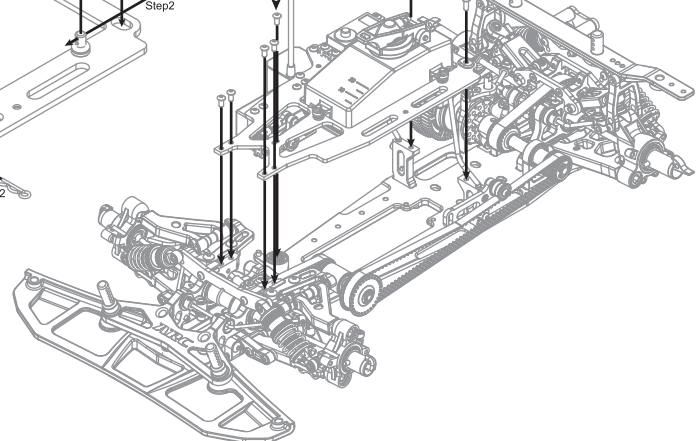

BAG 07

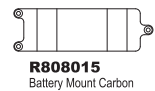

R808015
Battery Mount Carbon

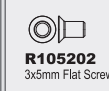

R105202
3x5mm Flat Screw

NiMH/Lipo Receiver Battery
(Not Included)

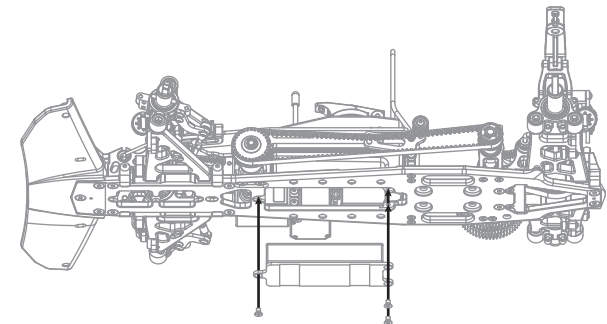
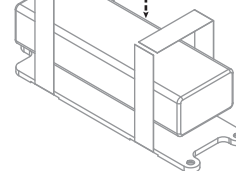

- R802012**
Engine Mount (2)
- R802001**
Fly Wheel
- R804001**
Clutch Pad Yellow
- R802100**
Spring Base
- R807001**
Spring 2.0mm
- R805304**
3x12mm
- R803004**
Fly Wheel Nut
- R802002**
Clutch Pad Base
- R804002**
Clutch Fly Weight
- R803006**
Clutch Spring Nut

BAG 07

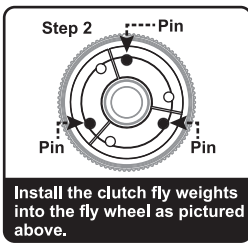
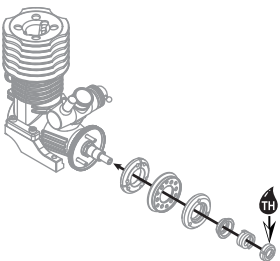
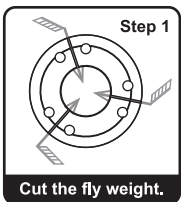
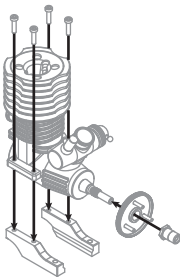

- R803002**
Clutch Bearing Nut
- R802030**
Clutch Bell -Alu
- R802070**
1st Gear Pinion 19T
- R802080**
2nd Gear Pinion 24T

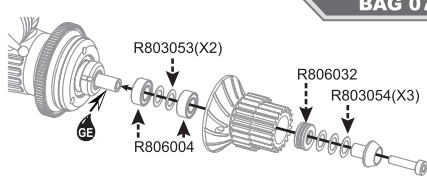
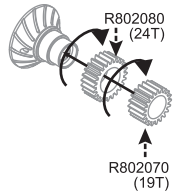

BAG 07

- R806032**
5x8x4mm
Thrust Bearing
- R806004**
5x10x4mm
Ball Bearing
(Metal Seal) (2)
- R803053**
5x8x0.1mm
- R803054**
5x8x0.2mm
- R805304**
3x12mm

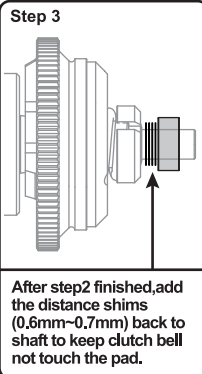
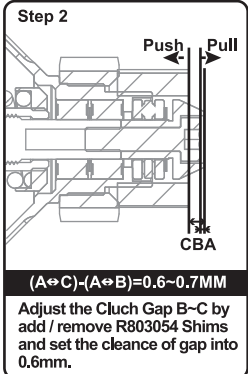
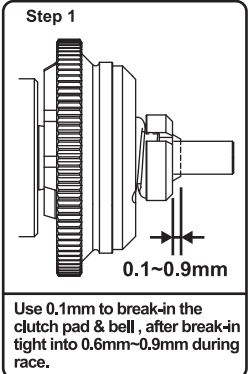

BAG 07

- R802057**
Break Lever
- R804035**
Fuel Tube
- R807006**
Throttle Linkage (2)
- R102006**
Collar Alu
- R801100**
Throttle Servo Horn Set
- R805300**
2.5x8mm
- R105401**
3x3mm Set

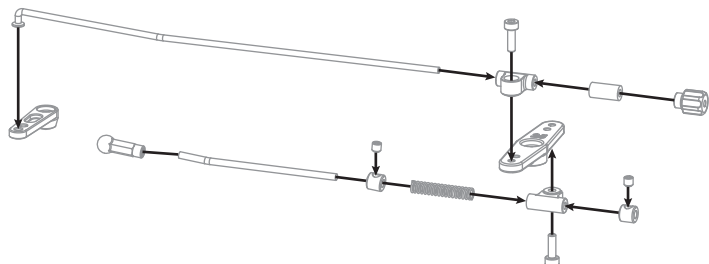

- R802035**
4mm Sink Shims Alu
- R805201**
4x8mm Flat Screw
- R105104**
3x6 Round Screw

Countersunk shims Alu.

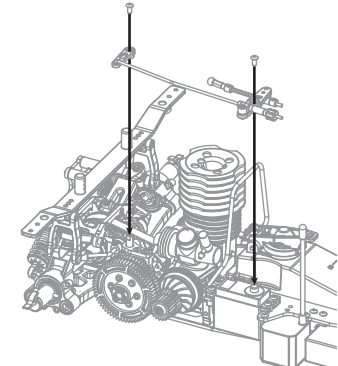
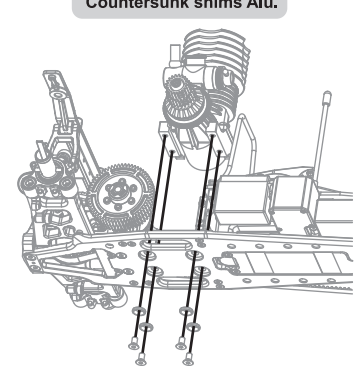

BAG 07

- R807033**
Exhaust Pipe Spring
- R805050**
4x4mm Set

Engine Not Included

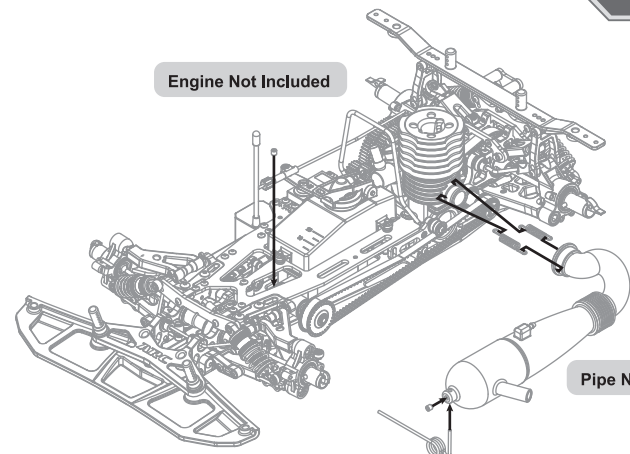

BAG 07

- R804004**
Body Mount Screw(4)
- R804035**
Fuel Tube 90cm

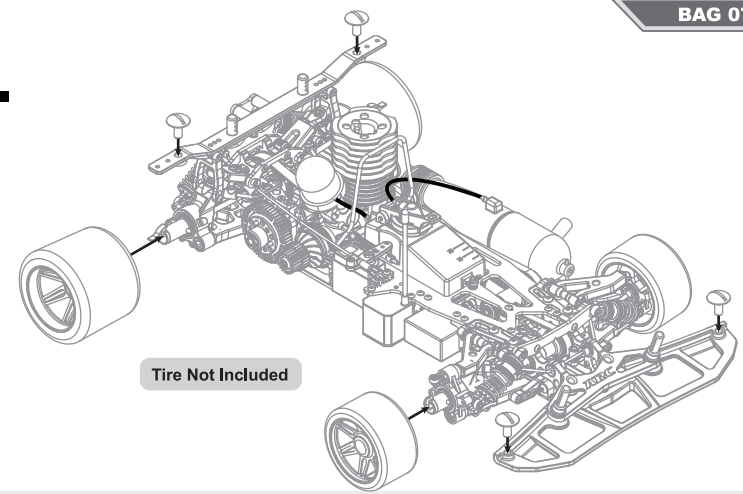

RACE

TRACK

NAME

CITY / COUNTRY

DATE

TEMPERATURE	AIR	TRACK	
QUALIFYING POSITION	BEST LAPTIME	FINAL POSITION	
SEC		MIN	
TRACK CONDITION	<input type="checkbox"/> TECHNICAL	<input type="checkbox"/> MIXED	<input type="checkbox"/> FAST
TRACTION	<input type="checkbox"/> LOW	<input checked="" type="checkbox"/> MEDIUM	<input type="checkbox"/> HIGH

GEAR RATIO CHART

Spur	Spur 1st	Spur 2nd
Pinion	60 61 62 56 57 58	
1st 19T	<input type="checkbox"/> 7.26 <input checked="" type="checkbox"/> 7.38 <input type="checkbox"/> 7.51	5.37 5.46 5.56
2nd 24T		<input type="checkbox"/> <input checked="" type="checkbox"/> <input type="checkbox"/>

SHOCK

Oil: 1 HOLE 2 HOLE

Shock Piston: 1 HOLE 2 HOLE

Spring: Red Blue

Hole Size: 1 HOLE 2 HOLE

TIRE

Front Left	32	Tire Shore	Rear Left	35
Front Right	32		Rear Right	35
Front Left	68 mm	Tire Ø	Rear Left	75 mm
Front Right	68 mm		Rear Right	75 mm

Tire Additive:

BODY

Bumper: Standard Cut

Body Mount Distance: 25 mm

Body: TS040 WING

Wing: 6 mm

ENGINE

Engine	NOVA VIRTUS	Pipe	EFRA 2015
Plug	C8TGH	Carb Dia	8.5 mm
Fuel	TORNANDO	Head Shims	0.7 mm

CLUTCH

Clutch Bell	Aluminum	Clutch Shoes	YELLOW
Spring Load	0.8 mm	Bell Clearance	0.6 mm

NOTE

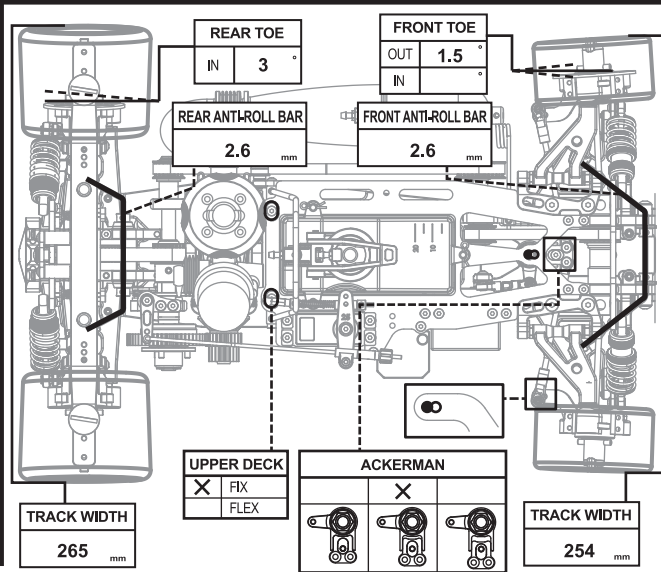
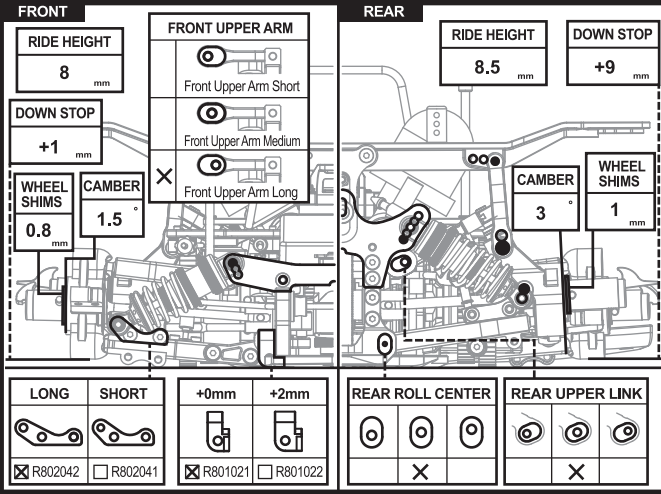
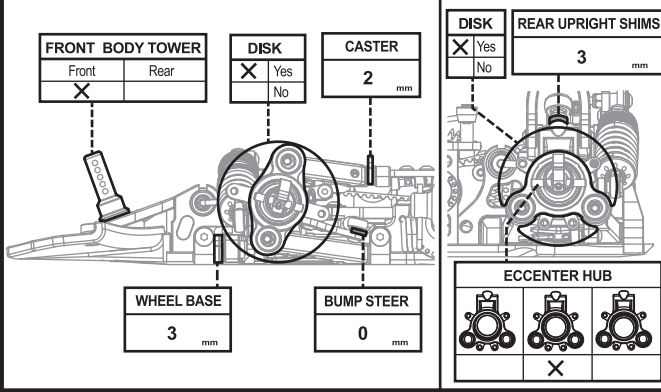

RACE

TRACK

NAME

CITY / COUNTRY

DATE

TEMPERATURE	AIR	TRACK	
QUALIFYING POSITION	BEST LAPTIME	FINAL POSITION	
SEC		MIN	
TRACK CONDITION	<input type="checkbox"/> TECHNICAL	<input type="checkbox"/> MIXED	<input type="checkbox"/> FAST
TRACTION	<input type="checkbox"/> LOW	<input type="checkbox"/> MEDIUM	<input type="checkbox"/> HIGH

GEAR RATIO CHART

Spur	Spur 1st	Spur 2nd
Pinion	60 61 62 56 57 58	
1st 19T	<input type="checkbox"/> 7.26 <input type="checkbox"/> 7.38 <input type="checkbox"/> 7.51	5.37 5.46 5.56
2nd 24T		<input type="checkbox"/> <input type="checkbox"/> <input type="checkbox"/>

SHOCK

Oil: 1 HOLE 2 HOLE

Shock Piston: 1 HOLE 2 HOLE

Spring: Red Blue

Hole Size: 1 HOLE 2 HOLE

TIRE

Front Left		Tire Shore	Rear Left	
Front Right			Rear Right	
Front Left		Tire Ø	Rear Left	
Front Right			Rear Right	

Tire Additive:

BODY

Bumper: Standard Cut

Body Mount Distance:

Body: R802042 R802041

Wing: R801021 R801022

ENGINE

Engine		Pipe	
Plug		Carb Dia	
Fuel		Head Shims	

CLUTCH

Clutch Bell		Clutch Shoes	
Spring Load		Bell Clearance	

NOTE

