

RACE

TRACK

NAME

CITY

DATE

TEMPERATURE AIR  TRACK

QUALIFYING  BEST LAP TIME  FINAL  RACE LENGTH

SEC MIN

TRACK CONDITION  CARPET  ASPHALT  INDOOR  OUTDOOR

BUMPY  SMOOTH

TECHNICAL  MIXED  FAST

TRACTION  LOW  MEDIUM  HIGH

FRONT TRANSMISSION REAR

GEAR DIFF  GEAR DIFF

CST  CST

ONE WAY  SPOOL Nbr of Gears  2  4

MOTOR  ESC

PINION DP  T  SPUR GEAR DP  T

FINAL DRIVE RATIO (IR = 2.0)

FRONT REAR

CST OIL  CST

SPRING

PISTON

% REBOUND  %

TIRES

TIRES

RIMS

INSERTS

ADDITIVE

SURFACE

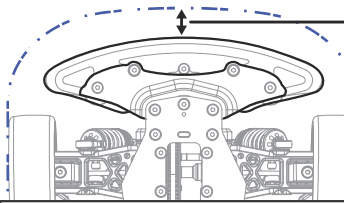

DISTANCE  mm

Bumper  Standard  Cut

BODY WING

ATS SETUP

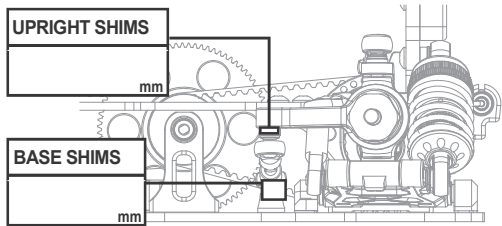

UPRIGHT SHIMS  mm

BASE SHIMS  mm

Active Toe  →

