

RACE

TRACK

NAME

CITY

DATE

TEMPERATURE AIR TRACK

QUALIFYING BEST LAP TIME FINAL RACE LENGTH

TRACK CONDITION CARPET ASPHALT INDOOR OUTDOOR BUMPY SMOOTH TECHNICAL MIXED FAST

TRACTION LOW MEDIUM HIGH

FRONT TRANSMISSION REAR

GEAR DIFF GEAR DIFF

CST CST

ONE WAY SPOOL Nbr of Gears 2 4

MOTOR ESC

PINION DP T SPUR GEAR DP T

FINAL DRIVE RATIO (IR = 2.0)

FRONT REAR

CST OIL CST

SPRING

PISTON

% REBOUND %

TIRES

TIRES

RIMS

INSERTS

ADDITIVE

SURFACE

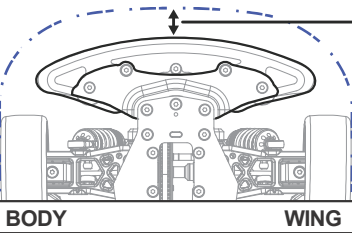

DISTANCE mm

Bumper Standard Cut

BODY WING

ACTIVE TOE

UPRIGHT SHIMS

BASE SHIMS

Active Toe 

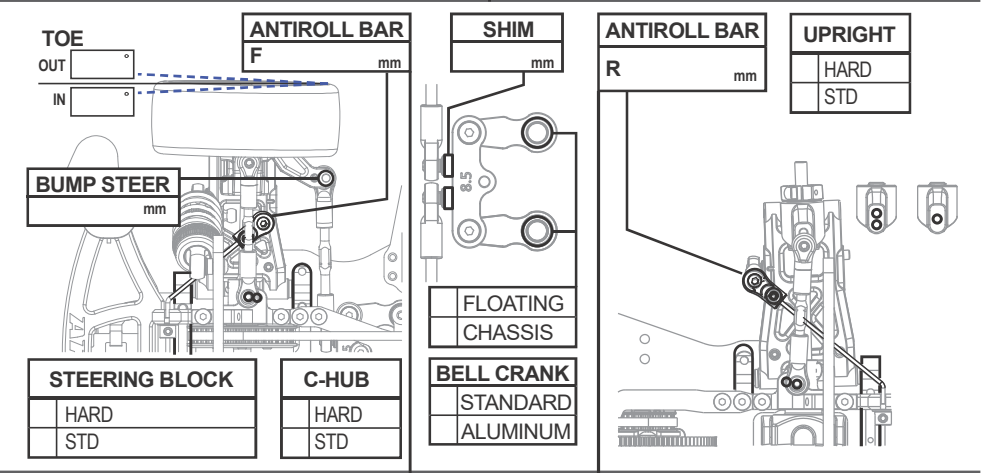
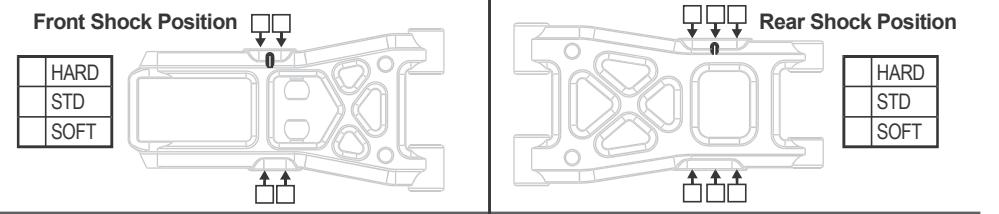
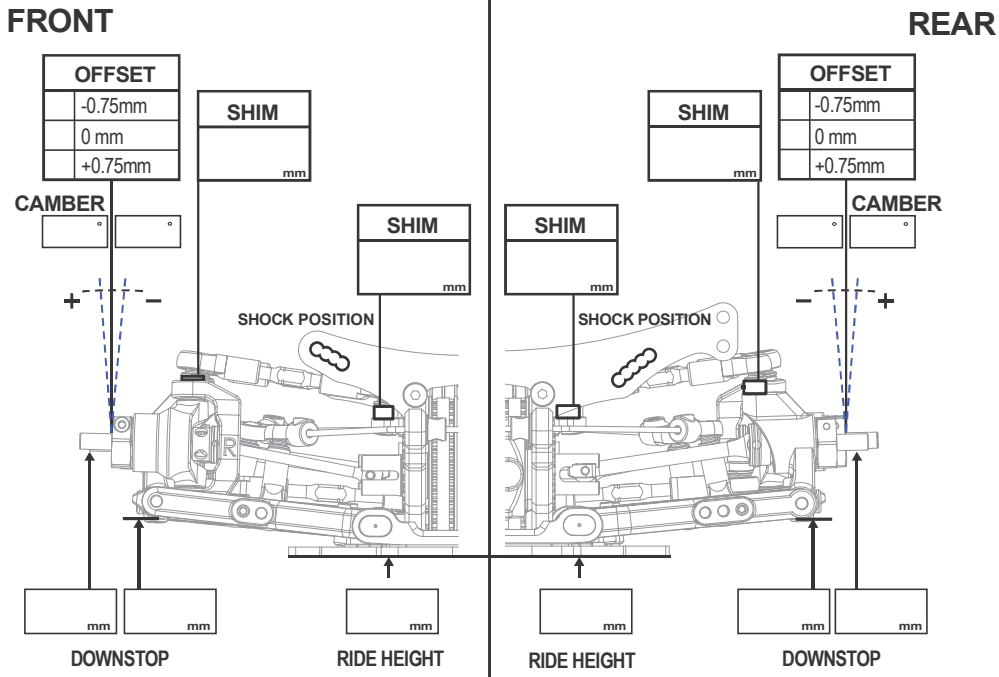

SUPENSION INSERT CHART

FRONT BLOCK

FR Z ++2 TP ++10 T+ ++1 S+ ++5 * * ++5 S+ ++3 T+ ++15 ST+ ++2 Z+

FF Z ++2 TP ++10 T+ ++1 S+ ++5 * * ++5 S+ ++3 T+ ++15 ST+ ++2 Z+

REAR BLOCK

RR Z ++2 TP ++10 T+ ++1 S+ ++5 * * ++5 S+ ++3 T+ ++15 ST+ ++2 Z+

RF Z ++2 TP ++10 T+ ++1 S+ ++5 * * ++5 S+ ++3 T+ ++15 ST+ ++2 Z+

