

R11 2018 SET-UP SHEET

1/10 Electric Touring Car

ARC

RACE **National Championship Indoor 2018**
 TRACK **TRCBK**
 NAME **Helge Johannessen**
 CITY / COUNTRY **Norway**
 DATE **20180415**

TEMPERATURE	AIR	TRACK
QUALIFYING POSITION	BEST LAP TIME	FINAL POSITION
1	12,81 SEC	1
RACE LENGTH 5 MIN		
TRACK CONDITION		
<input type="checkbox"/> TECHNICAL	<input checked="" type="checkbox"/> CARPET	<input type="checkbox"/> ASPHALT
<input type="checkbox"/> LOW	<input checked="" type="checkbox"/> MIXED	<input type="checkbox"/> FAST
TRACTION <input type="checkbox"/> LOW <input checked="" type="checkbox"/> MEDIUM <input type="checkbox"/> HIGH		

FRONT		REAR	
TRANSMISSION			
GEAR DIFF		GEAR DIFF	
<input type="checkbox"/>	CST	<input checked="" type="checkbox"/>	10000 CST
ONE WAY		Number of Gears	
<input checked="" type="checkbox"/>	SPOOL	<input type="checkbox"/>	2 <input checked="" type="checkbox"/> 4

PINION	19 T	SPUR GEAR	85 T
FINAL DRIVE RATIO		8.95	

FRONT		REAR	
40 CST	OIL	40 CST	
2,5/2,7	SPRING	2,8	
PDS	PISTON	PDS	
0 %	REBOUND	0 %	

Volante	TIRES	Volante
	RIM	
	INSERTS	
CS High	ADDITIVE	CS High

BODY MOUNT DISTANCE **+10mm** mm

Bumper Standard Cut

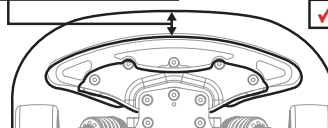

BODY **Altis 2,3e** WING **Std**

ATS SETUP

UPRIGHT SHIMS mm

BASE SHIMS mm

Active Toe →

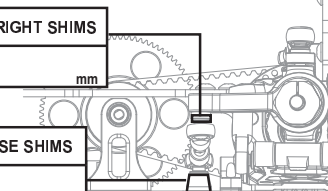

NOTE

Drilled hole in top of damper. LF links, LF pulley set, 2 joint cvd's rear. Brass suspension mounts rear. Rear screw in motor mount.

FRONT

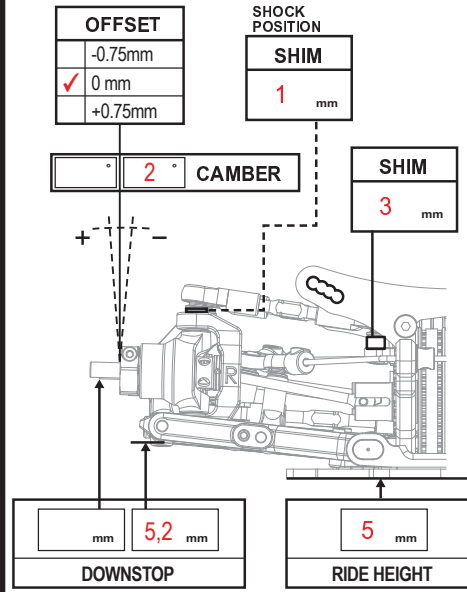

REAR

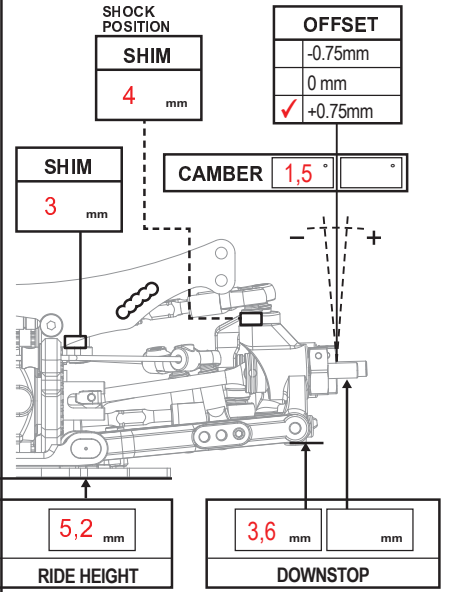

Front Shock Position

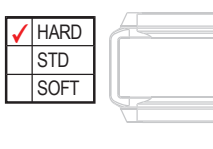

Rear Shock Position

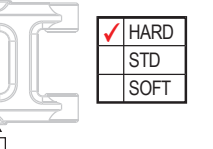

TOE OUT **1,5** °

ANTIROLL BAR F **1,3** mm

SHIM **0** mm

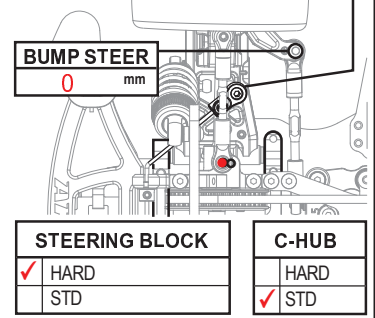

ANTIROLL BAR R **1,3** mm

UPRIGHT: HARD STD

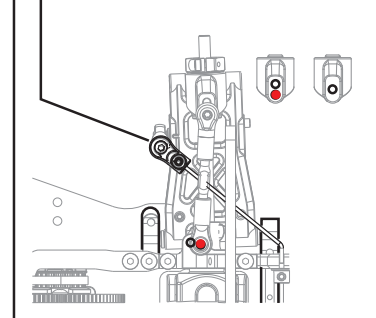

SUPENSION INSERT CHART

FRONT BLOCK	
FR	<input type="checkbox"/> Z++ <input checked="" type="checkbox"/> ++2 <input type="checkbox"/> ++1 <input type="checkbox"/> +1 <input type="checkbox"/> 0 <input type="checkbox"/> -1 <input type="checkbox"/> -2 <input type="checkbox"/> -3 <input type="checkbox"/> -4 <input type="checkbox"/> -5 <input type="checkbox"/> -6 <input type="checkbox"/> -7 <input type="checkbox"/> -8 <input type="checkbox"/> -9 <input type="checkbox"/> -10 <input type="checkbox"/> -11 <input type="checkbox"/> -12 <input type="checkbox"/> -13 <input type="checkbox"/> -14 <input type="checkbox"/> -15 <input type="checkbox"/> -16 <input type="checkbox"/> -17 <input type="checkbox"/> -18 <input type="checkbox"/> -19 <input type="checkbox"/> -20 <input type="checkbox"/> -21 <input type="checkbox"/> -22 <input type="checkbox"/> -23 <input type="checkbox"/> -24 <input type="checkbox"/> -25 <input type="checkbox"/> -26 <input type="checkbox"/> -27 <input type="checkbox"/> -28 <input type="checkbox"/> -29 <input type="checkbox"/> -30 <input type="checkbox"/> -31 <input type="checkbox"/> -32 <input type="checkbox"/> -33 <input type="checkbox"/> -34 <input type="checkbox"/> -35 <input type="checkbox"/> -36 <input type="checkbox"/> -37 <input type="checkbox"/> -38 <input type="checkbox"/> -39 <input type="checkbox"/> -40 <input type="checkbox"/> -41 <input type="checkbox"/> -42 <input type="checkbox"/> -43 <input type="checkbox"/> -44 <input type="checkbox"/> -45 <input type="checkbox"/> -46 <input type="checkbox"/> -47 <input type="checkbox"/> -48 <input type="checkbox"/> -49 <input type="checkbox"/> -50 <input type="checkbox"/> -51 <input type="checkbox"/> -52 <input type="checkbox"/> -53 <input type="checkbox"/> -54 <input type="checkbox"/> -55 <input type="checkbox"/> -56 <input type="checkbox"/> -57 <input type="checkbox"/> -58 <input type="checkbox"/> -59 <input type="checkbox"/> -60 <input type="checkbox"/> -61 <input type="checkbox"/> -62 <input type="checkbox"/> -63 <input type="checkbox"/> -64 <input type="checkbox"/> -65 <input type="checkbox"/> -66 <input type="checkbox"/> -67 <input type="checkbox"/> -68 <input type="checkbox"/> -69 <input type="checkbox"/> -70 <input type="checkbox"/> -71 <input type="checkbox"/> -72 <input type="checkbox"/> -73 <input type="checkbox"/> -74 <input type="checkbox"/> -75 <input type="checkbox"/> -76 <input type="checkbox"/> -77 <input type="checkbox"/> -78 <input type="checkbox"/> -79 <input type="checkbox"/> -80 <input type="checkbox"/> -81 <input type="checkbox"/> -82 <input type="checkbox"/> -83 <input type="checkbox"/> -84 <input type="checkbox"/> -85 <input type="checkbox"/> -86 <input type="checkbox"/> -87 <input type="checkbox"/> -88 <input type="checkbox"/> -89 <input type="checkbox"/> -90 <input type="checkbox"/> -91 <input type="checkbox"/> -92 <input type="checkbox"/> -93 <input type="checkbox"/> -94 <input type="checkbox"/> -95 <input type="checkbox"/> -96 <input type="checkbox"/> -97 <input type="checkbox"/> -98 <input type="checkbox"/> -99 <input type="checkbox"/> -100
FF	<input type="checkbox"/> Z++ <input checked="" type="checkbox"/> ++2 <input type="checkbox"/> ++1 <input type="checkbox"/> +1 <input type="checkbox"/> 0 <input type="checkbox"/> -1 <input type="checkbox"/> -2 <input type="checkbox"/> -3 <input type="checkbox"/> -4 <input type="checkbox"/> -5 <input type="checkbox"/> -6 <input type="checkbox"/> -7 <input type="checkbox"/> -8 <input type="checkbox"/> -9 <input type="checkbox"/> -10 <input type="checkbox"/> -11 <input type="checkbox"/> -12 <input type="checkbox"/> -13 <input type="checkbox"/> -14 <input type="checkbox"/> -15 <input type="checkbox"/> -16 <input type="checkbox"/> -17 <input type="checkbox"/> -18 <input type="checkbox"/> -19 <input type="checkbox"/> -20 <input type="checkbox"/> -21 <input type="checkbox"/> -22 <input type="checkbox"/> -23 <input type="checkbox"/> -24 <input type="checkbox"/> -25 <input type="checkbox"/> -26 <input type="checkbox"/> -27 <input type="checkbox"/> -28 <input type="checkbox"/> -29 <input type="checkbox"/> -30 <input type="checkbox"/> -31 <input type="checkbox"/> -32 <input type="checkbox"/> -33 <input type="checkbox"/> -34 <input type="checkbox"/> -35 <input type="checkbox"/> -36 <input type="checkbox"/> -37 <input type="checkbox"/> -38 <input type="checkbox"/> -39 <input type="checkbox"/> -40 <input type="checkbox"/> -41 <input type="checkbox"/> -42 <input type="checkbox"/> -43 <input type="checkbox"/> -44 <input type="checkbox"/> -45 <input type="checkbox"/> -46 <input type="checkbox"/> -47 <input type="checkbox"/> -48 <input type="checkbox"/> -49 <input type="checkbox"/> -50 <input type="checkbox"/> -51 <input type="checkbox"/> -52 <input type="checkbox"/> -53 <input type="checkbox"/> -54 <input type="checkbox"/> -55 <input type="checkbox"/> -56 <input type="checkbox"/> -57 <input type="checkbox"/> -58 <input type="checkbox"/> -59 <input type="checkbox"/> -60 <input type="checkbox"/> -61 <input type="checkbox"/> -62 <input type="checkbox"/> -63 <input type="checkbox"/> -64 <input type="checkbox"/> -65 <input type="checkbox"/> -66 <input type="checkbox"/> -67 <input type="checkbox"/> -68 <input type="checkbox"/> -69 <input type="checkbox"/> -70 <input type="checkbox"/> -71 <input type="checkbox"/> -72 <input type="checkbox"/> -73 <input type="checkbox"/> -74 <input type="checkbox"/> -75 <input type="checkbox"/> -76 <input type="checkbox"/> -77 <input type="checkbox"/> -78 <input type="checkbox"/> -79 <input type="checkbox"/> -80 <input type="checkbox"/> -81 <input type="checkbox"/> -82 <input type="checkbox"/> -83 <input type="checkbox"/> -84 <input type="checkbox"/> -85 <input type="checkbox"/> -86 <input type="checkbox"/> -87 <input type="checkbox"/> -88 <input type="checkbox"/> -89 <input type="checkbox"/> -90 <input type="checkbox"/> -91 <input type="checkbox"/> -92 <input type="checkbox"/> -93 <input type="checkbox"/> -94 <input type="checkbox"/> -95 <input type="checkbox"/> -96 <input type="checkbox"/> -97 <input type="checkbox"/> -98 <input type="checkbox"/> -99 <input type="checkbox"/> -100
REAR BLOCK	
RR	<input type="checkbox"/> Z++ <input checked="" type="checkbox"/> ++2 <input type="checkbox"/> ++1 <input type="checkbox"/> +1 <input type="checkbox"/> 0 <input type="checkbox"/> -1 <input type="checkbox"/> -2 <input type="checkbox"/> -3 <input type="checkbox"/> -4 <input type="checkbox"/> -5 <input type="checkbox"/> -6 <input type="checkbox"/> -7 <input type="checkbox"/> -8 <input type="checkbox"/> -9 <input type="checkbox"/> -10 <input type="checkbox"/> -11 <input type="checkbox"/> -12 <input type="checkbox"/> -13 <input type="checkbox"/> -14 <input type="checkbox"/> -15 <input type="checkbox"/> -16 <input type="checkbox"/> -17 <input type="checkbox"/> -18 <input type="checkbox"/> -19 <input type="checkbox"/> -20 <input type="checkbox"/> -21 <input type="checkbox"/> -22 <input type="checkbox"/> -23 <input type="checkbox"/> -24 <input type="checkbox"/> -25 <input type="checkbox"/> -26 <input type="checkbox"/> -27 <input type="checkbox"/> -28 <input type="checkbox"/> -29 <input type="checkbox"/> -30 <input type="checkbox"/> -31 <input type="checkbox"/> -32 <input type="checkbox"/> -33 <input type="checkbox"/> -34 <input type="checkbox"/> -35 <input type="checkbox"/> -36 <input type="checkbox"/> -37 <input type="checkbox"/> -38 <input type="checkbox"/> -39 <input type="checkbox"/> -40 <input type="checkbox"/> -41 <input type="checkbox"/> -42 <input type="checkbox"/> -43 <input type="checkbox"/> -44 <input type="checkbox"/> -45 <input type="checkbox"/> -46 <input type="checkbox"/> -47 <input type="checkbox"/> -48 <input type="checkbox"/> -49 <input type="checkbox"/> -50 <input type="checkbox"/> -51 <input type="checkbox"/> -52 <input type="checkbox"/> -53 <input type="checkbox"/> -54 <input type="checkbox"/> -55 <input type="checkbox"/> -56 <input type="checkbox"/> -57 <input type="checkbox"/> -58 <input type="checkbox"/> -59 <input type="checkbox"/> -60 <input type="checkbox"/> -61 <input type="checkbox"/> -62 <input type="checkbox"/> -63 <input type="checkbox"/> -64 <input type="checkbox"/> -65 <input type="checkbox"/> -66 <input type="checkbox"/> -67 <input type="checkbox"/> -68 <input type="checkbox"/> -69 <input type="checkbox"/> -70 <input type="checkbox"/> -71 <input type="checkbox"/> -72 <input type="checkbox"/> -73 <input type="checkbox"/> -74 <input type="checkbox"/> -75 <input type="checkbox"/> -76 <input type="checkbox"/> -77 <input type="checkbox"/> -78 <input type="checkbox"/> -79 <input type="checkbox"/> -80 <input type="checkbox"/> -81 <input type="checkbox"/> -82 <input type="checkbox"/> -83 <input type="checkbox"/> -84 <input type="checkbox"/> -85 <input type="checkbox"/> -86 <input type="checkbox"/> -87 <input type="checkbox"/> -88 <input type="checkbox"/> -89 <input type="checkbox"/> -90 <input type="checkbox"/> -91 <input type="checkbox"/> -92 <input type="checkbox"/> -93 <input type="checkbox"/> -94 <input type="checkbox"/> -95 <input type="checkbox"/> -96 <input type="checkbox"/> -97 <input type="checkbox"/> -98 <input type="checkbox"/> -99 <input type="checkbox"/> -100
RF	<input type="checkbox"/> Z++ <input checked="" type="checkbox"/> ++2 <input type="checkbox"/> ++1 <input type="checkbox"/> +1 <input type="checkbox"/> 0 <input type="checkbox"/> -1 <input type="checkbox"/> -2 <input type="checkbox"/> -3 <input type="checkbox"/> -4 <input type="checkbox"/> -5 <input type="checkbox"/> -6 <input type="checkbox"/> -7 <input type="checkbox"/> -8 <input type="checkbox"/> -9 <input type="checkbox"/> -10 <input type="checkbox"/> -11 <input type="checkbox"/> -12 <input type="checkbox"/> -13 <input type="checkbox"/> -14 <input type="checkbox"/> -15 <input type="checkbox"/> -16 <input type="checkbox"/> -17 <input type="checkbox"/> -18 <input type="checkbox"/> -19 <input type="checkbox"/> -20 <input type="checkbox"/> -21 <input type="checkbox"/> -22 <input type="checkbox"/> -23 <input type="checkbox"/> -24 <input type="checkbox"/> -25 <input type="checkbox"/> -26 <input type="checkbox"/> -27 <input type="checkbox"/> -28 <input type="checkbox"/> -29 <input type="checkbox"/> -30 <input type="checkbox"/> -31 <input type="checkbox"/> -32 <input type="checkbox"/> -33 <input type="checkbox"/> -34 <input type="checkbox"/> -35 <input type="checkbox"/> -36 <input type="checkbox"/> -37 <input type="checkbox"/> -38 <input type="checkbox"/> -39 <input type="checkbox"/> -40 <input type="checkbox"/> -41 <input type="checkbox"/> -42 <input type="checkbox"/> -43 <input type="checkbox"/> -44 <input type="checkbox"/> -45 <input type="checkbox"/> -46 <input type="checkbox"/> -47 <input type="checkbox"/> -48 <input type="checkbox"/> -49 <input type="checkbox"/> -50 <input type="checkbox"/> -51 <input type="checkbox"/> -52 <input type="checkbox"/> -53 <input type="checkbox"/> -54 <input type="checkbox"/> -55 <input type="checkbox"/> -56 <input type="checkbox"/> -57 <input type="checkbox"/> -58 <input type="checkbox"/> -59 <input type="checkbox"/> -60 <input type="checkbox"/> -61 <input type="checkbox"/> -62 <input type="checkbox"/> -63 <input type="checkbox"/> -64 <input type="checkbox"/> -65 <input type="checkbox"/> -66 <input type="checkbox"/> -67 <input type="checkbox"/> -68 <input type="checkbox"/> -69 <input type="checkbox"/> -70 <input type="checkbox"/> -71 <input type="checkbox"/> -72 <input type="checkbox"/> -73 <input type="checkbox"/> -74 <input type="checkbox"/> -75 <input type="checkbox"/> -76 <input type="checkbox"/> -77 <input type="checkbox"/> -78 <input type="checkbox"/> -79 <input type="checkbox"/> -80 <input type="checkbox"/> -81 <input type="checkbox"/> -82 <input type="checkbox"/> -83 <input type="checkbox"/> -84 <input type="checkbox"/> -85 <input type="checkbox"/> -86 <input type="checkbox"/> -87 <input type="checkbox"/> -88 <input type="checkbox"/> -89 <input type="checkbox"/> -90 <input type="checkbox"/> -91 <input type="checkbox"/> -92 <input type="checkbox"/> -93 <input type="checkbox"/> -94 <input type="checkbox"/> -95 <input type="checkbox"/> -96 <input type="checkbox"/> -97 <input type="checkbox"/> -98 <input type="checkbox"/> -99 <input type="checkbox"/> -100

