

RACE

TRACK

NAME

CITY

DATE

TEMPERATURE		AIR		TRACK	
QUALIFYING	BEST LAP TIME	FINAL	RACE LENGTH		
	SEC		MIN		

TRACK CONDITION

CARPET  ASPHALT  INDOOR  OUTDOOR

BUMPY  SMOOTH

TECHNICAL  MIXED  FAST

TRACTION  LOW  MEDIUM  HIGH

FRONT	TRANSMISSION	REAR
<input type="checkbox"/> GEAR DIFF	<input type="checkbox"/> GEAR DIFF	
<input type="text"/> CST	<input type="text"/> CST	
<input type="checkbox"/> ONE WAY	<input type="checkbox"/> SPOOL	Nbr of Gears <input type="checkbox"/> 2 <input type="checkbox"/> 4

MOTOR	ESC		
PINION DP	T	SPUR GEAR DP	T
FINAL DRIVE RATIO (IR = 2.0)			

FRONT	REAR
<input type="text"/> CST	<input type="text"/> CST
<input type="text"/> OIL	<input type="text"/> OIL
<input type="text"/> SPRING	<input type="text"/> SPRING
<input type="text"/> PISTON	<input type="text"/> PISTON
<input type="text"/> % REBOUND	<input type="text"/> % REBOUND

TIRES

TIRES

RIM

INSERTS

ADDITIVE

SURFACE

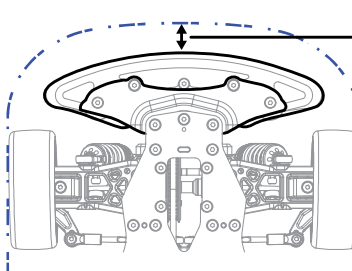

BODY MOUNT DISTANCE	<input type="text"/> mm
Bumper	<input type="checkbox"/> Standard <input type="checkbox"/> Cut
BODY	WING

ATS SETUP

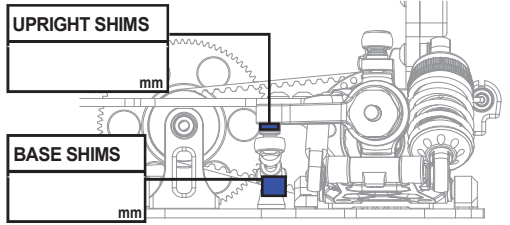

UPRIGHT SHIMS  mm

BASE SHIMS  mm

