

RACE

TRACK

NAME

CITY

DATE

TEMPERATURE		AIR	TRACK	
QUALIFYING	BEST LAP TIME	FINAL	RACE LENGTH	
	SEC		MIN	

TRACK CONDITION

CARPET ASPHALT INDOOR OUTDOOR

BUMPY SMOOTH

TECHNICAL MIXED FAST

TRACTION LOW MEDIUM HIGH

FRONT	TRANSMISSION	REAR
<input type="checkbox"/> GEAR DIFF	<input type="checkbox"/> GEAR DIFF	
<input type="text"/> CST	<input type="text"/> CST	
<input type="checkbox"/> ONE WAY	<input type="checkbox"/> SPOOL	Nbr of Gears <input type="checkbox"/> 2 <input type="checkbox"/> 4

MOTOR	ESC		
PINION DP	T	SPUR GEAR DP	T
FINAL DRIVE RATIO (IR = 2.0)			

FRONT	REAR
<input type="text"/> CST	<input type="text"/> CST
<input type="text"/> OIL	<input type="text"/> OIL
<input type="text"/> SPRING	<input type="text"/> SPRING
<input type="text"/> PISTON	<input type="text"/> PISTON
<input type="text"/> % REBOUND	<input type="text"/> % REBOUND

TIRES

TIRES

RIM

INSERTS

ADDITIVE

SURFACE

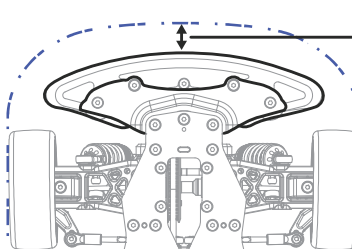

BODY MOUNT DISTANCE mm

Bumper Standard Cut

BODY	WING
------	------

ATS SETUP

UPRIGHT SHIMS mm

BASE SHIMS mm

