

RACE

TRACK

NAME

CITY

DATE

TEMPERATURE	AIR	TRACK
QUALIFYING	BEST LAP TIME	FINAL POSITION
	SEC	MIN
TRACK CONDITION		
<input type="checkbox"/> CARPET	<input type="checkbox"/> ASPHALT	
<input type="checkbox"/> INDOOR	<input type="checkbox"/> OUTDOOR	
<input type="checkbox"/> TECHNICAL	<input type="checkbox"/> MIXED	<input type="checkbox"/> FAST
TRACTION <input type="checkbox"/> LOW	<input type="checkbox"/> MEDIUM	<input type="checkbox"/> HIGH

FRONT	TRANSMISSION	REAR
GEAR DIFF		GEAR DIFF
<input type="checkbox"/>	CST	<input type="checkbox"/>
<input type="checkbox"/> ONE WAY	Number of Gears	
<input type="checkbox"/> SPOOL	<input type="checkbox"/> 2 <input type="checkbox"/> 4	

MOTOR	ESC
PINION DP	T
SPUR GEAR DP	T
FINAL DRIVE RATIO (Internal Ratio: 2.0)	

FRONT	REAR
OIL <input type="checkbox"/> 3 HOLE <input type="checkbox"/> 4 HOLE	SHOCK PISTON <input type="checkbox"/> 3 HOLE <input type="checkbox"/> 4 HOLE
HOLE SIZE	
mm	mm
mm	mm
SPRING	SPRING

TIRES	
RIM	
INSERTS	
ADDITIVE	

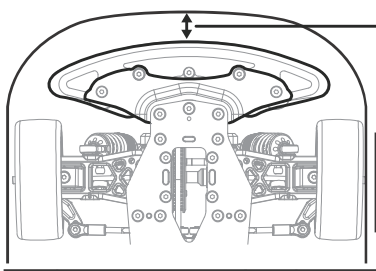

Bumper

Standard

Cut

BODY MOUNT DISTANCE

mm

BODY

WING

ATS SETUP

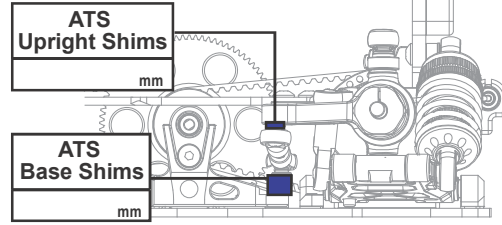

ATS Upright Shims

mm

ATS Base Shims

mm

