

RACE

TRACK

NAME

CITY / COUNTRY

DATE

TEMPERATURE	AIR	TRACK
QUALIFYING POSITION	BEST LAP TIME	FINAL POSITION
	SEC	MIN

TRACK CONDITION

TECHNICAL  CARPET  ASPHALT

MIXED  FAST

TRACTION  LOW  MEDIUM  HIGH

FRONT	REAR
TRANSMISSION	
GEAR DIFF	GEAR DIFF
<input type="text"/>	<b>1000</b>
CST	CST
<input type="checkbox"/> ONE WAY	Number of Gears
<input checked="" type="checkbox"/> SPOOL	<input type="checkbox"/> 2 <input checked="" type="checkbox"/> 4

PINION	T	SPUR GEAR	T
R10 Internal Ratio		<b>2.0</b>	
FINAL DRIVE RATIO			

OIL	FRONT	REAR
<b>500</b>	<input type="checkbox"/> 3 HOLE	<input type="checkbox"/> 3 HOLE
CST	<input checked="" type="checkbox"/> 4 HOLE	<input checked="" type="checkbox"/> 4 HOLE
	OIL	<b>500</b>
	CST	
SPRING	SHOCK PISTON	SHOCK PISTON
<b>BLUE</b>	<input checked="" type="checkbox"/> <b>1.1</b> mm	<input type="checkbox"/> mm
	mm	
	SPRING	<b>BLUE</b>

	TIRES
	RIM
	INSERTS
	ADDITIVE

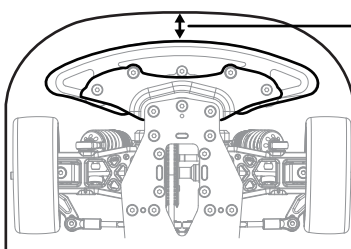

**Bumper**

Standard

Cut

**BODY MOUNT DISTANCE**

**8** mm

BODY **BLITZ LSF** WING **STANDARD**

### ATS SETUP

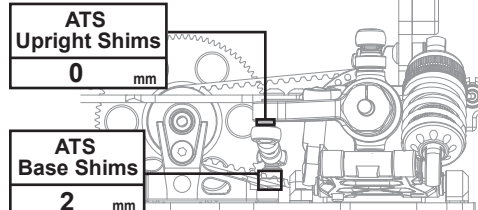

**ATS Upright Shims**

**0** mm

**ATS Base Shims**

**2** mm

**NOTE**

